

# Metal Structures

## Design Project I

### Steel truss – examples of calculation (part I)

# Algorithm

Calculation of each metal structure can be divided into few groups of problem:

- ◆ Initial assumptions about geometry of structure (initial drawing);
- ◆ Analysis of loads and actions;
- ◆ Calculation of elements (resistance, stability, deflection);
- ◆ Calculation of connections and joints between elements (stiffness, resistance);
- ◆ Final drawings and documentatnion;

→ Des #1 / 11

6 examples of calculations for various sub-parts of steel truss will be presented:

I<sup>st</sup> example: roofing selection;

II<sup>nd</sup> example: purlin

III<sup>rd</sup> example: truss member;

IV<sup>th</sup> example: roof bracing.

V<sup>th</sup> example: node;

VI<sup>th</sup> example: field splice;

Theoretical explanations of above problems will be detaily presented during lectures, here are way of calculation only.

## General notices:

Loads and actions are applicated in different ways to:

- roofing panels  $q_r$  [kN / m<sup>2</sup>];
- purlins  $q_p$  [kN / m];
- truss girder  $F$  [kN].

These loads come from:

- dead-weight of structure;
- snow load;
- wind action;
- imposed loads during repairing.

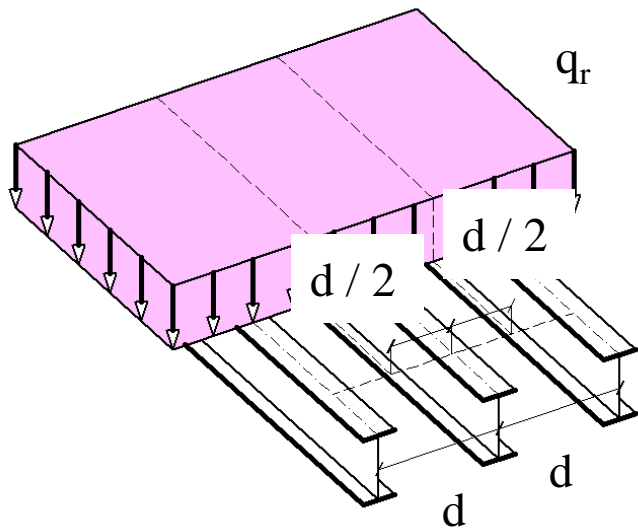
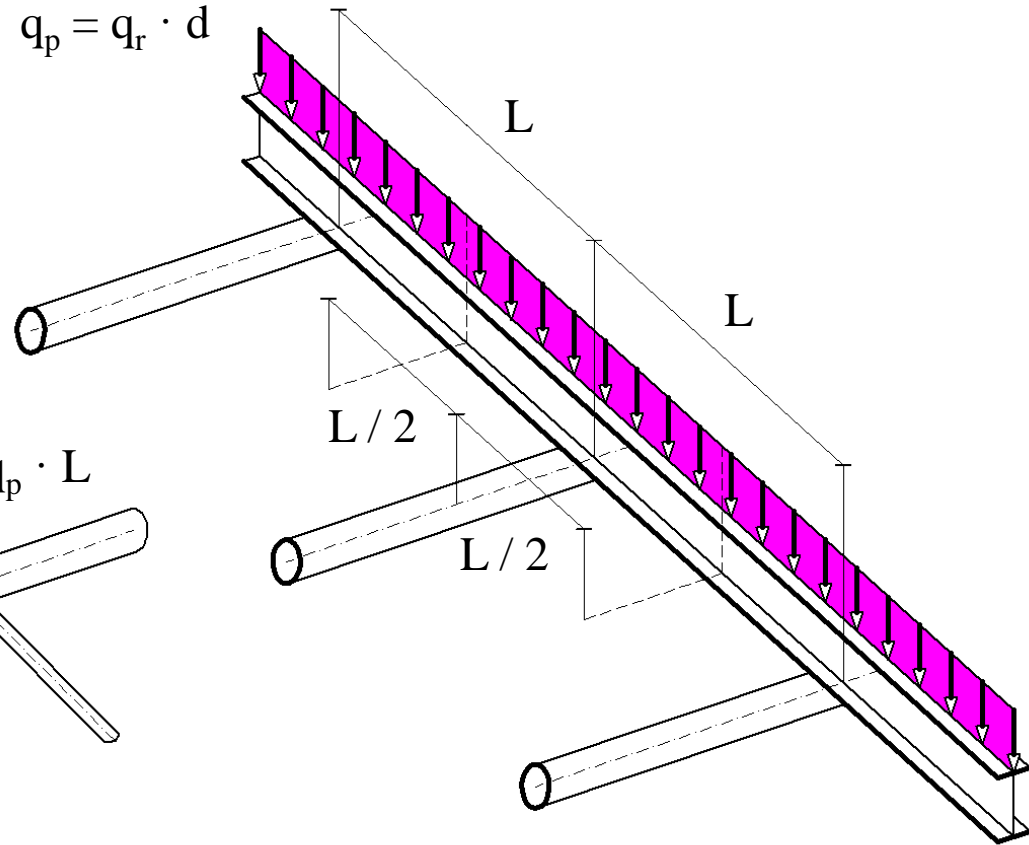
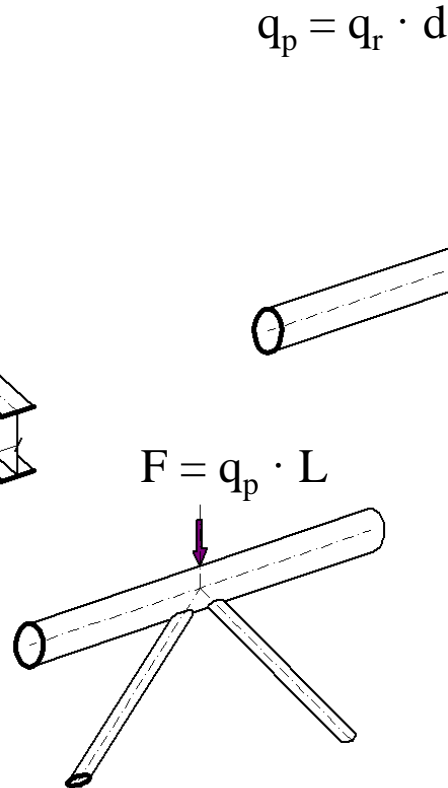

Photo: Author



Dead-weight:

Sandwich panels, min thickness in data, adjusted to larger value when resistance is checking.

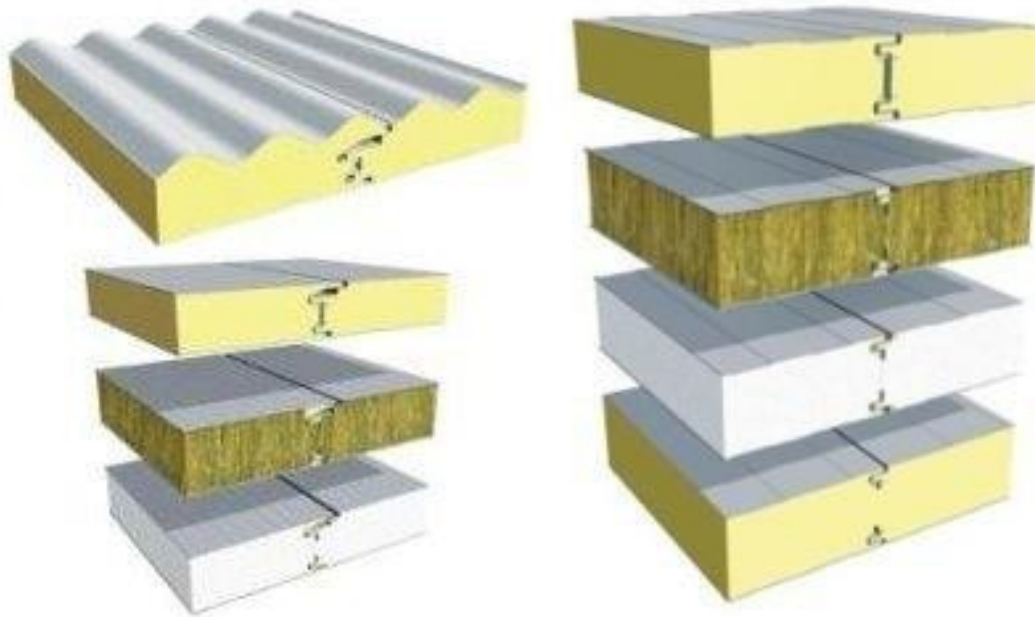

Photo: steelprofil.eu

Dead-weight:

Purlins: IPE, initial assumption  $h = l_p / 20 - l_p / 25$ , this means IPE 240 - 300 in analysed case. Such dead-weight can be accepted even if final  $h$  will be other.

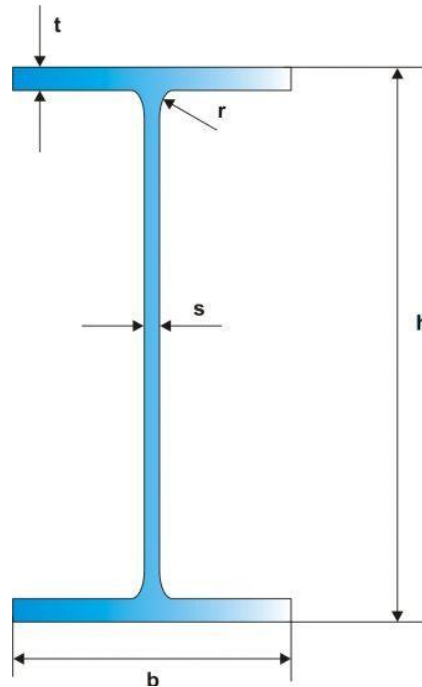

Photo: hmsteel.pl

## Dead-weight of truss

I<sup>st</sup> proposal (PN B 02001):

$$g_T = [ 2 / a + 0,12 (g + q) ] L / 100$$

$g_T$  (dead-weight of all trusses per area of roof),  $g$  (roofing + purlins),  $q$  (snow + wind) → [kN/m<sup>2</sup>], characteristic values

$a$  (distance between trusses),  $L$  (truss span) → [m]

II<sup>nd</sup> proposal:

$$g_{T1} = d_{\text{steel}} q_1 L^3 / (2 H f_y)$$

$g_{T1}$  (dead-weight of one truss) → [kN],  $d_{\text{steel}}$  own weight of steel → [kN/m<sup>3</sup>],  $H$  – height of truss (vertical distance between top and bottom chord) → [m]

→ Des #1 / 29

$$q_1 = a(g + q)$$

$$g_{T1} \approx a L g_T$$

We must analyse symmetrical and antisymmetrical loads from snow.

EN 1991-1-3 fig. 5.3

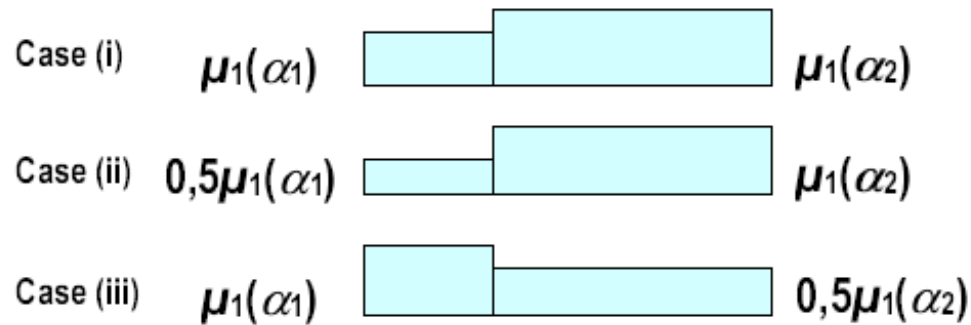

→ Des #1 / 35

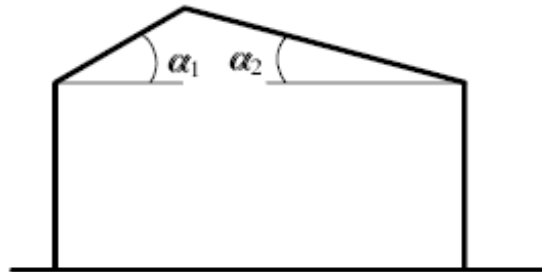

We must analyse wind parallel and perpendicular to longitudinal axis of building.

EN 1991-1-4 fig. 7.5, 7.8

→ Des #1 / 34

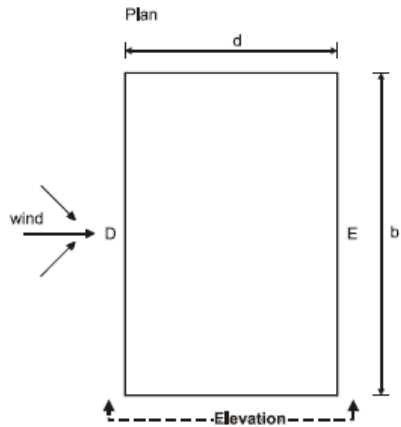

$e = b$  or  $2h$ ,  
whichever is smaller

$b$ : crosswind dimension

**Elevation for  $e < d$**

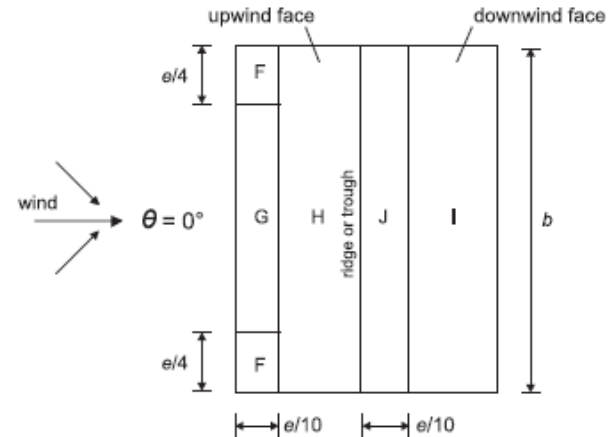
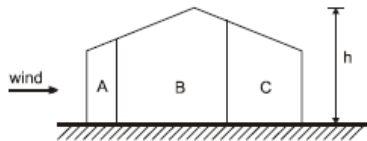
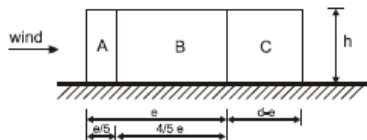

(b) wind direction  $\theta = 0^\circ$

$e = b$  or  $2h$   
whichever is smaller

$b$ : crosswind dimension

**Elevation for  $e > d$**

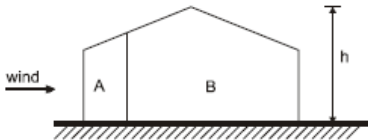
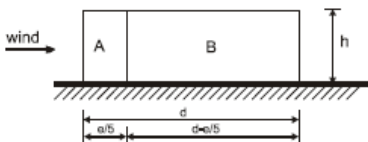

**Elevation for  $e \geq 5d$**

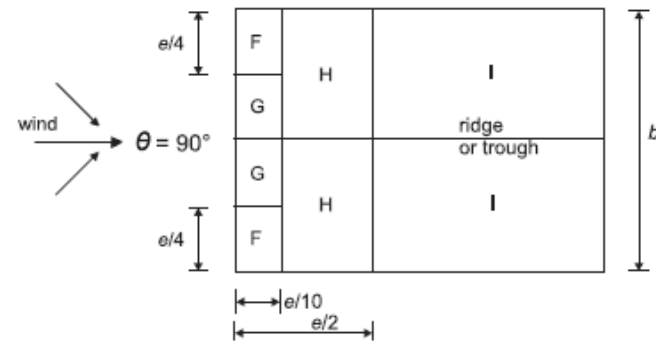
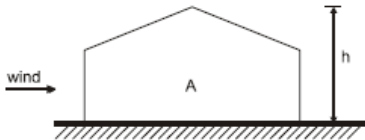
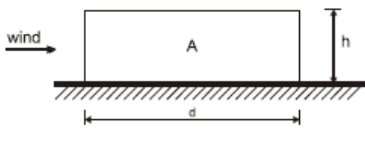

(c) wind direction  $\theta = 90^\circ$

Reminder from Introduction to Construction Design:

Combinations of actions and loads for analysed case:

Case E	G (dead weight)		Q (live load)					
			Wind		Snow		Imposed load on roof	
	$\gamma_{Gi}$	$\Psi_i$	$\gamma_{Wi}$	$\Psi_i$	$\gamma_{Si}$	$\Psi_i$	$\gamma_{Ii}$	$\Psi_i$
<b>ULS (resistance)</b>								
1	1,35	1,00	1,50	0,60	1,50	1,00	1,50	0,00
2	1,35	1,00	1,50	0,60	1,50	0,00	1,50	1,00
3	1,00	1,00	1,50	1,00	1,50	0,00	1,50	0,00
<b>SLS (deformation)</b>								
4	1,00	1,00	1,00	0,20	1,00	0,20	1,00	0,00

1, 2, 4 – wind pressure

3 – wind suction

$$E = \sum (\gamma_{ij} \Psi_{ij} F_i)$$

## I<sup>st</sup> example of calculations – roofing selection

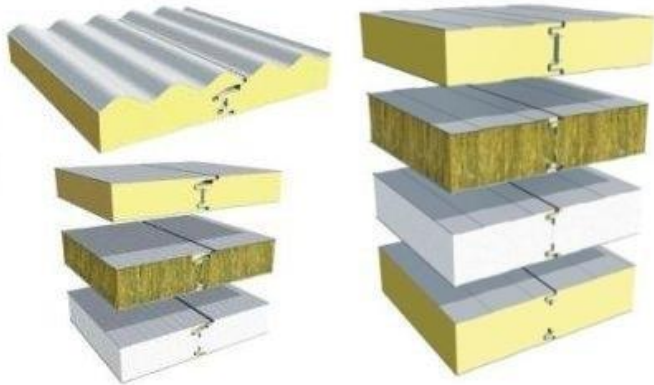

Photo: steelprofil.eu

- $t_{\min} \geq 11 \text{ cm}$  (data in topic)
- Fire resistance EI30 (the same for everybody)
- Distance between purlins = 2,10 m (initial drawing)

Conditions for checking:

- resistance:  $E / R \leq 1,0$
- deflection:  $E / R \leq 1,0$
- fire resistance: non smaller than EI30

$$s_k = 2,00 \text{ kN} / \text{m}^2$$

$$w_k = 0,18 \text{ kN} / \text{m}^2 \text{ (pressure)}$$

$$w_k = 0,21 \text{ kN} / \text{m}^2 \text{ (suction)}$$

For roofing  $t = 11 \text{ cm}$ , estimation:

$$g_k = 0,11 \text{ kN} / \text{m}^2$$

Imposed load (the same for everybody):

$$q_k = 0,60 \text{ kN} / \text{m}^2$$

Simplification: we disregard differences in way of loads are applied, and for roofing panels we consider simple sum of the values.

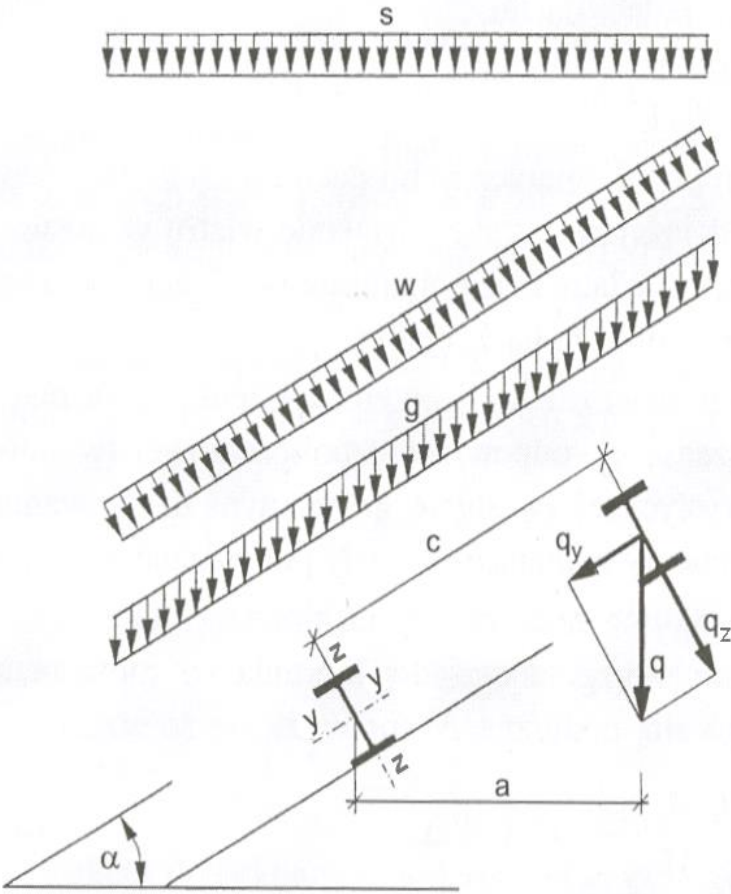

Photo: M. Łubiński, W. Żółtowski, Konstrukcje Metalowe t. II, Arkady, Warszawa 2004

According #t / 10:

Case	g	w	s	i	$\Sigma$
<b>ULS (resistance)</b>					
1 (w↓)	$0,11 \cdot 1,35 \cdot 1,0 =$ $= 0,149$	$0,18 \cdot 1,50 \cdot 0,6 =$ $= 0,162$	$2,00 \cdot 1,50 \cdot 1,0 =$ $= 3,000$	$0,60 \cdot 1,50 \cdot 0,0 =$ $= 0,000$	<b>3,311</b>
2 (w↓)	$0,11 \cdot 1,35 \cdot 1,0 =$ $= 0,149$	$0,18 \cdot 1,50 \cdot 0,6 =$ $= 0,162$	$2,00 \cdot 1,50 \cdot 0,0 =$ $= 0,000$	$0,60 \cdot 1,50 \cdot 1,0 =$ $= 0,900$	1,211
3 (w↑)	$0,11 \cdot 1,00 \cdot 1,0 =$ $= 0,110$	$-0,21 \cdot 1,50 \cdot 1,0 =$ $= -0,210$	$2,00 \cdot 1,50 \cdot 0,0 =$ $= 0,000$	$0,60 \cdot 1,50 \cdot 0,0 =$ $= 0,000$	<b>-0,100</b>
<b>SLS (deformation)</b>					
3 (w↓)	$0,11 \cdot 1,00 \cdot 1,0 =$ $= 0,110$	$0,18 \cdot 1,00 \cdot 0,2 =$ $= 0,036$	$2,00 \cdot 1,0 \cdot 0,2 =$ $= 0,400$	$0,60 \cdot 1,50 \cdot 0,0 =$ $= 0,000$	<b>0,546</b>

Tables propose **10 or 12 cm** thick sandwich panels. With the minimum required thickness of 11 cm - the second (12 cm) should be chosen.

One-span panels, PWD-PIR 120, thickness of thermal isolation 120 mm, thickness of metal layers 0,5 / 0,4 mm, distance between purlins 2,10 m, resistances in kN/m<sup>2</sup>

**Tablica 5** Maksymalne obciążenia JEDNOPRZESŁOWYCH płyt dachowych PWD-PIR 120 grubość okładzin 0,5/0,4 mm  
Dwa lub trzy łączniki. Różnica temperatur uwzględniona w obliczeniach.

Photo: pruszyński.com.pl

**OBCIĄŻENIE W KIERUNKU OD PODPORY - SSANIE / DO PODPORY - PARCIE**



Płyta dachowa PWD-PIR 120

Grupa kolorów	Warunki obciążenia	Obciążenie kN/m <sup>2</sup> w zależności od rozpiętości																				
		1,5	1,8	2,1	2,4	2,7	3,0	3,3	3,6	3,9	4,2	4,5	4,8	5,1	5,4	5,7	6,0	6,3	6,6	6,9	7,2	
Grupa I kolory bardzo jasne	parcie	SGU	13,03	9,74	7,55	6,03	4,89	4,01	3,32	2,77	2,33	1,97	1,66	1,38	1,15	0,96	0,80	0,66	0,51	0,38	0,27	0,18
		SGN	7,16	6,06	5,27	4,64	4,11	3,66	3,26	2,93	2,63	2,36	2,13	1,92	1,74	1,58	1,44	1,31	1,19	1,10	1,01	0,92
	ssanie	SGU	13,28	9,99	7,82	6,28	5,13	4,26	3,57	3,02	2,58	2,22	1,93	1,68	1,48	1,31	1,16	1,04	0,93	0,84	0,77	0,70
		SGN	5,85	4,89	4,22	3,69	3,30	2,99	2,72	2,51	2,33	2,16	1,91	1,68	1,50	1,35	1,23	1,11	1,02	0,95	0,87	0,81
Grupa II kolory jasne	parcie	SGU	13,03	9,74	7,55	6,03	4,89	4,01	3,32	2,77	2,33	1,97	1,66	1,38	1,15	0,96	0,80	0,66	0,51	0,38	0,27	0,18
		SGN	7,16	6,06	5,27	4,64	4,11	3,66	3,26	2,93	2,63	2,36	2,13	1,92	1,74	1,58	1,44	1,31	1,19	1,10	1,01	0,92
	ssanie	SGU	13,28	9,99	7,82	6,28	5,13	4,26	3,57	3,02	2,58	2,22	1,93	1,68	1,48	1,31	1,16	1,04	0,93	0,84	0,76	0,66
		SGN	5,85	4,89	4,22	3,69	3,30	2,99	2,72	2,51	2,33	2,16	1,91	1,68	1,50	1,35	1,23	1,11	1,02	0,95	0,87	0,81
Grupa III kolory ciemne	parcie	SGU	13,03	9,74	7,55	6,03	4,89	4,01	3,32	2,77	2,33	1,97	1,66	1,38	1,15	0,96	0,80	0,66	0,51	0,38	0,27	0,18
		SGN	7,16	6,06	5,27	4,64	4,11	3,66	3,26	2,93	2,63	2,36	2,13	1,92	1,74	1,58	1,44	1,31	1,19	1,10	1,01	0,92
	ssanie	SGU	13,28	9,99	7,82	6,28	5,13	4,26	3,57	3,02	2,58	2,22	1,93	1,68	1,38	1,13	0,92	0,76	0,62	0,51	0,42	0,35
		SGN	5,85	4,89	4,22	3,69	3,30	2,99	2,72	2,51	2,33	2,16	1,91	1,68	1,50	1,35	1,23	1,11	1,02	0,95	0,87	0,81

Pressure, Ultimate Limit State (resistance), Serviceability Limit State (deflection)

Suction, Ultimate Limit State (resistance), Serviceability Limit State (deflection)

Existed load / Resistance  
 must be  
 $\leq 1,0$

		Downward		Upward	
ULS	E	3,311	$3,311 / 5,27 =$ $= 0,628$ 	0,100	$0,100 / 4,22 =$ $= 0,024$ 
	R	5,27		4,22	
SLS	E	0,546	$0,546 / 7,55 =$ $= 0,072$ 		Not analysed; E will be much more smaller than for ULS, so effort will be much more smaller than 0,024
	R	7,55		7,82	

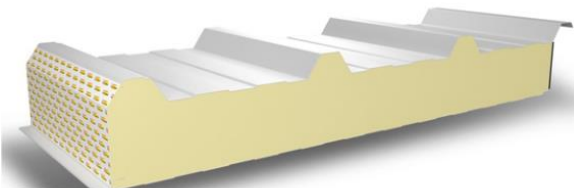

## PWD-PIR-120 - Płyta warstwowa dachowa - pianka poliuretanowa - widoczne mocowanie

rdzeń

poliuretan PIR

waga 1m<sup>2</sup>

Dead-weight

13,09 kg

profilowanie wew.

grubość płyty

120 mm

Thickness

PIRTECH - płyta warstwowa DACHOWA

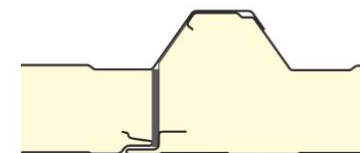

ZAMEK

Photo: pruszyński.com.pl

PWD-PIR 120

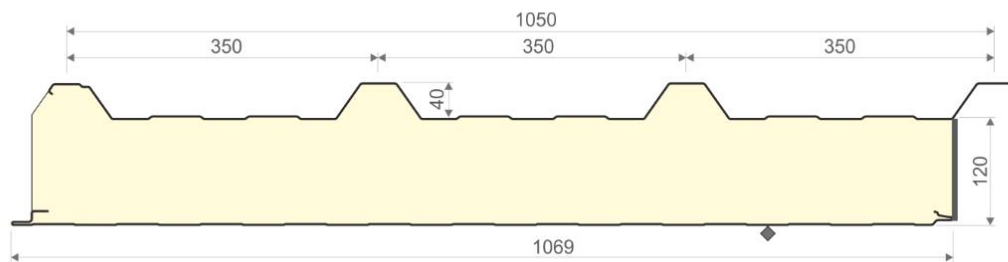

Odporność ogniowa

REI30/RE60

Fire resistance

## Conclusion:

Sandwich panel PWD-PIR 120 satisfies requirements for:

- resistance (max. effort 0,628)
- accepted deflection (max. effort 0,072)
- min. fire resistance (REI30 - RE60 means  $R = 60$ ,  $E = 60$ ,  $I = 30$ ; required EI30, this means  $E \geq 30$ ,  $I \geq 30$ ).

Dead-weight of panels is equal  $13,09 \text{ kg} / \text{m}^2$ , this means  $0,128 \text{ kN} / \text{m}^2$

Such value of dead-weight will be taken into analysis of purlins and truss girder.



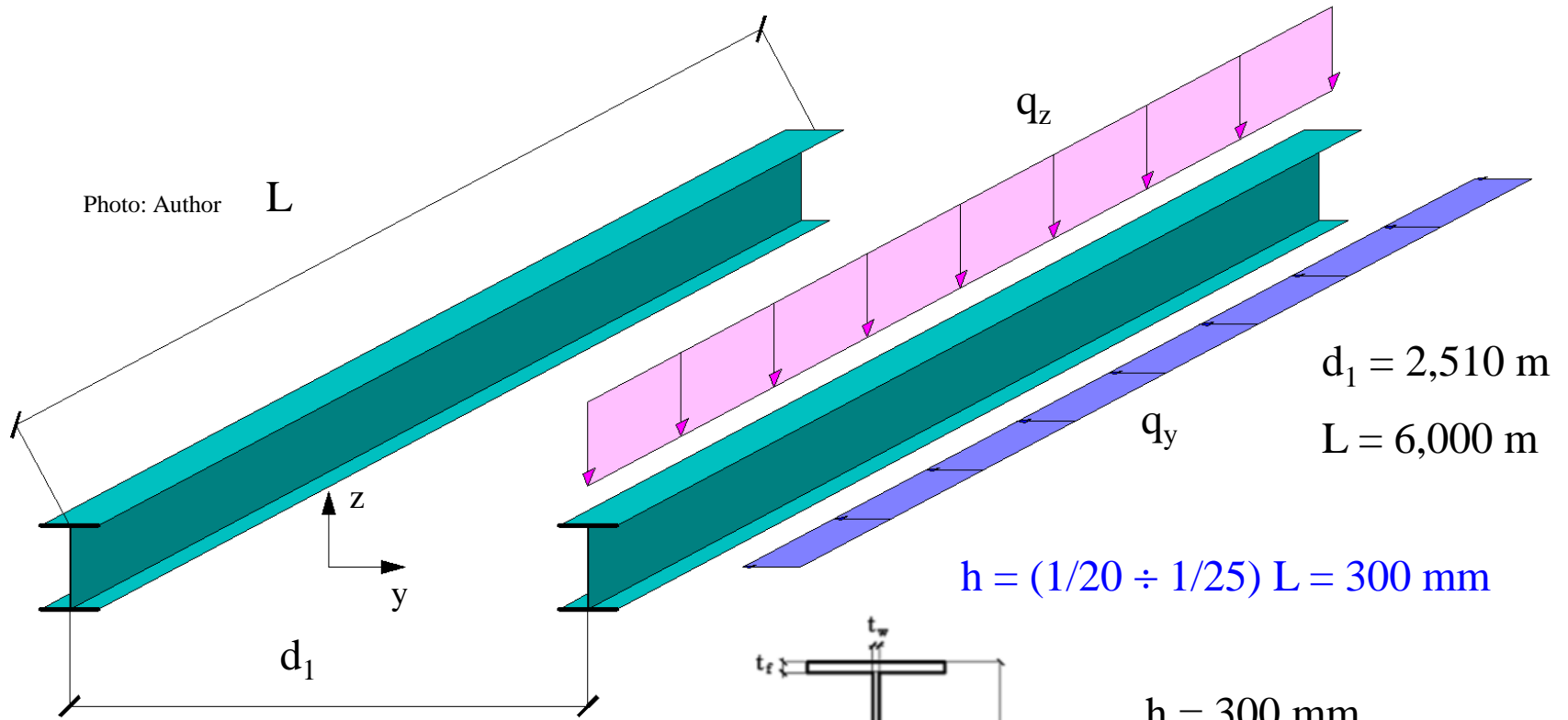

$$h = (1/20 \div 1/25) L = 300 \text{ mm}$$

IPE 300:

$J_y = 8356,0 \text{ cm}^4$

$J_z = 603,8 \text{ cm}^4$

$W_{pl, y} = 628,4 \text{ cm}^3$

$W_{pl, z} = 125,2 \text{ cm}^3$

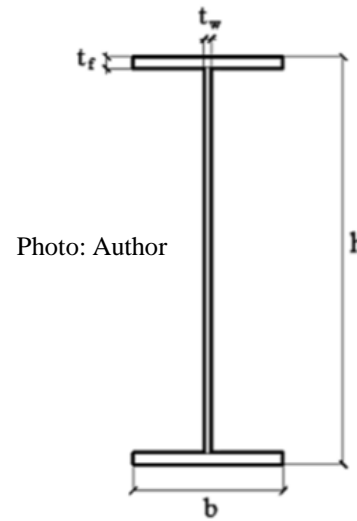

$h = 300 \text{ mm}$

$d = 150 \text{ mm}$

$t_w = 7,1 \text{ mm}$

$t_f = 10,7 \text{ mm}$

$A_{V, y} = 32,1 \text{ cm}^2$

$A_{V, z} = 21,3 \text{ cm}^2$

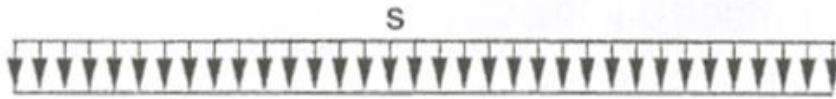
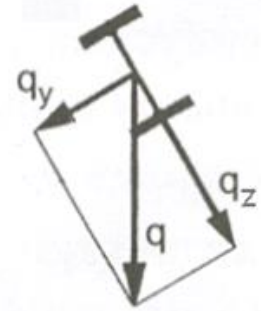
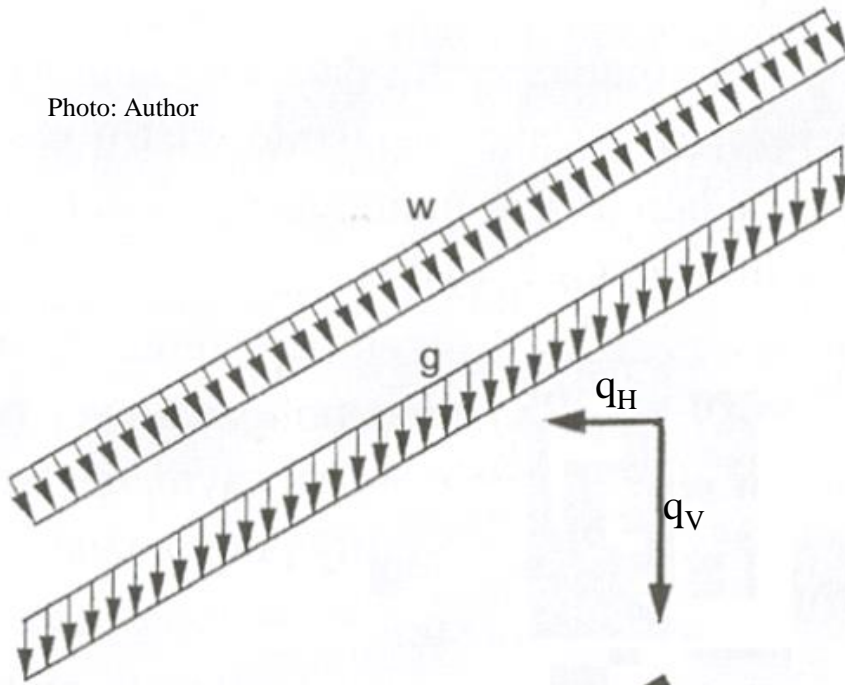

Photo: Author



$$s_k \rightarrow q_H, q_V ; l$$

$$g_k, i_k \rightarrow q_H, q_V ; l_1$$

$$w_k \rightarrow q_y, q_z ; l_1$$

$$l_1 = 2 (d_1 / 2) = d_1 = 2,51 \text{ m}$$

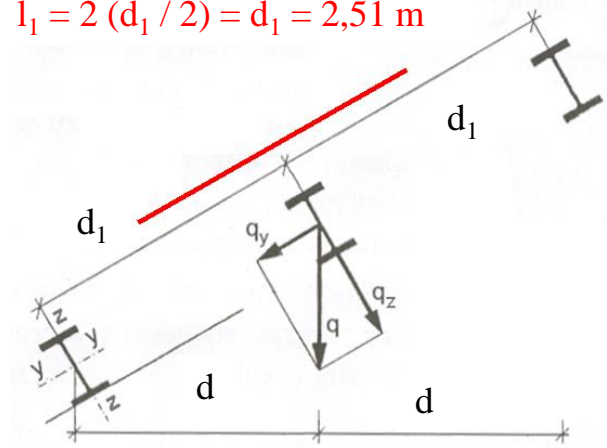

$$l = 2 (d / 2) = d = 2,50 \text{ m}$$

$$q_H(g_k) = 0,000 \text{ kN / m}$$

$$q_V(g_k) = g_k d_1 = 0,402 \text{ kN / m}$$

$$q_H(i_k) = 0,000 \text{ kN / m}$$

$$q_V(i_k) = i_k d_1 = 1,506 \text{ kN / m}$$

$$q_H(s_k) = 0,000 \text{ kN / m}$$

$$q_V(s_k) = s_k d = 6,250 \text{ kN / m}$$

$$q_y(w_k) = 0,000 / 0,000 \text{ kN / m}$$

$$q_z(w_k) = w_k d_1 = 0,502 \downarrow / 0,628 \uparrow \text{ kN / m}$$

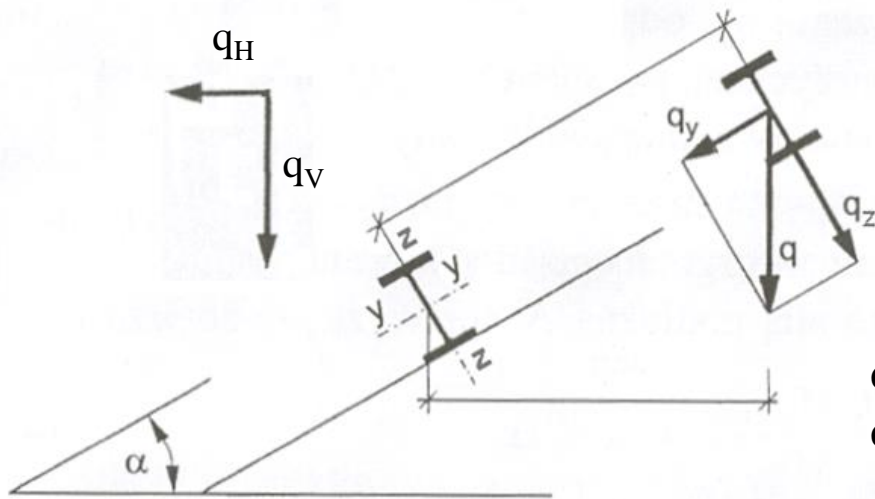

$$q_H \rightarrow q_y, q_z \quad ; \quad q_V \rightarrow q_y, q_z$$

$$q_y(q_H) = q_H \cos \alpha \quad ; \quad q_z(q_H) = - q_H \sin \alpha$$

$$q_y(q_V) = q_V \sin \alpha \quad ; \quad q_z(q_V) = q_V \cos \alpha$$

$$q_y[q_H(g_k)] = q_H(g_k) \cos \alpha = 0,000 \text{ kN / m}$$

$$q_z[q_H(g_k)] = - q_H(g_k) \sin \alpha = 0,000 \text{ kN / m}$$

$$q_y[q_V(g_k)] = q_V(g_k) \sin \alpha = 0,035 \text{ kN / m}$$

$$q_z[q_V(g_k)] = q_V(g_k) \cos \alpha = 0,400 \text{ kN / m}$$

$$q_y[q_H(s_k)] = q_H(s_k) \cos \alpha = 0,000 \text{ kN / m}$$

$$q_z[q_H(s_k)] = - q_H(s_k) \sin \alpha = 0,000 \text{ kN / m}$$

$$q_y[q_V(s_k)] = q_V(s_k) \sin \alpha = 0,544 \text{ kN / m}$$

$$q_z[q_V(s_k)] = q_V(s_k) \cos \alpha = 6,226 \text{ kN / m}$$

$$q_y[q_H(i_k)] = q_H(i_k) \cos \alpha = 0,000 \text{ kN / m}$$

$$q_z[q_H(i_k)] = - q_H(i_k) \sin \alpha = 0,000 \text{ kN / m}$$

$$q_y[q_V(i_k)] = q_V(i_k) \sin \alpha = 0,131 \text{ kN / m}$$

$$q_z[q_V(i_k)] = q_V(i_k) \cos \alpha = 1,500 \text{ kN / m}$$

	w	s	g	i
$q_{z, k}$ [kN / m]	0,502 ↓ 0,628 ↑	6,226	0,400	1,500
$q_{y, k}$ [kN / m]	0,000 0,000	0,544	0,035	0,131

Verification:

$q_{z, k}$  should be  $\gg q_{y, k}$

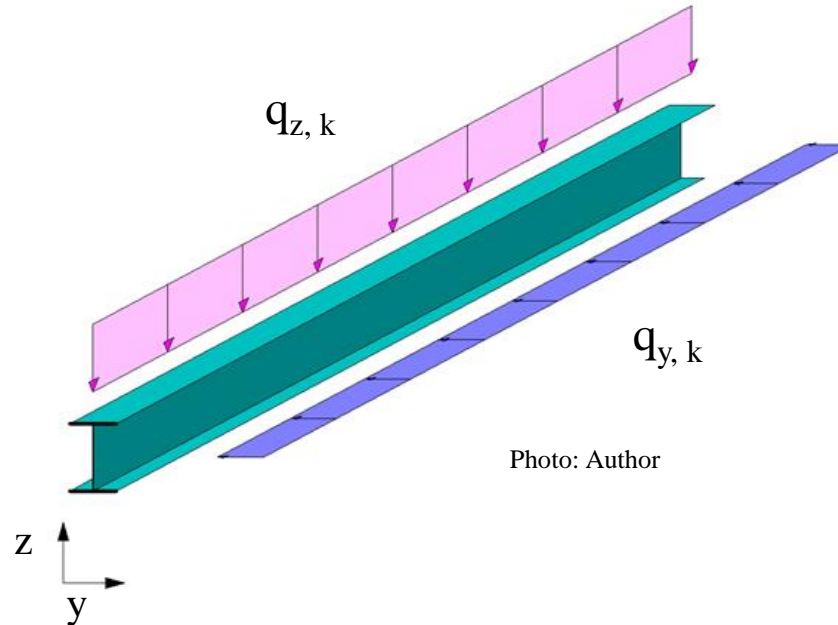

Photo: Author

According #t / 10:

Case		g	w	s	i	$\Sigma$
ULS (resistance)						
1 (w↓)	$q_z$ [kN / m]	$0,400 \cdot 1,35 \cdot 1,0 =$ $= 0,540$	$0,502 \cdot 1,50 \cdot 0,6 =$ $= 0,452$	$6,226 \cdot 1,50 \cdot 1,0 =$ $= 9,339$	$1,500 \cdot 1,50 \cdot 0,0 =$ $= 0,000$	10,331
	$q_y$ [kN / m]	$0,035 \cdot 1,35 \cdot 1,0 =$ $= 0,047$	0,000	$0,544 \cdot 1,50 \cdot 1,0 =$ $= 0,816$	$0,131 \cdot 1,50 \cdot 0,0 =$ $= 0,000$	0,863
2 (w↓)	$q_z$ [kN / m]	$0,400 \cdot 1,35 \cdot 1,0 =$ $= 0,540$	$0,502 \cdot 1,50 \cdot 0,6 =$ $= 0,452$	$6,226 \cdot 1,50 \cdot 0,0 =$ $= 0,000$	$1,500 \cdot 1,50 \cdot 1,0 =$ $= 2,245$	3,237
	$q_y$ [kN / m]	$0,035 \cdot 1,35 \cdot 1,0 =$ $= 0,047$	0,000	$0,544 \cdot 1,50 \cdot 0,0 =$ $= 0,000$	$0,131 \cdot 1,50 \cdot 1,0 =$ $= 0,197$	0,244
3 (w↑)	$q_z$ [kN / m]	$0,400 \cdot 1,00 \cdot 1,0 =$ $= 0,400$	$0,628 \cdot 1,50 \cdot 1,0 =$ $= -0,628$	$6,226 \cdot 1,50 \cdot 0,0 =$ $= 0,000$	$1,500 \cdot 1,50 \cdot 0,0 =$ $= 0,000$	-0,228 (absolute value smaller than in 1)
	$q_y$ [kN / m]	$0,035 \cdot 1,00 \cdot 1,0 =$ $= 0,035$	0,000	$0,544 \cdot 1,50 \cdot 0,0 =$ $= 0,000$	$0,131 \cdot 1,50 \cdot 0,0 =$ $= 0,000$	0,035
SLS (deformation)						
4 (w↓)	$q_z$ [kN / m]	$0,400 \cdot 1,00 \cdot 1,0 =$ $= 0,400$	$0,502 \cdot 1,00 \cdot 0,2 =$ $= 0,100$	$6,226 \cdot 1,00 \cdot 0,2 =$ $= 1,245$	$1,500 \cdot 1,50 \cdot 0,0 =$ $= 0,000$	1,745
	$q_y$ [kN / m]	$0,035 \cdot 1,00 \cdot 1,0 =$ $= 0,035$	0,000	$0,544 \cdot 1,00 \cdot 0,2 =$ $= 0,109$	$0,131 \cdot 1,50 \cdot 0,0 =$ $= 0,000$	0,144

$$q_z = 10,331 \text{ kN / m}$$

$$q_y = 0,863 \text{ kN / m}$$

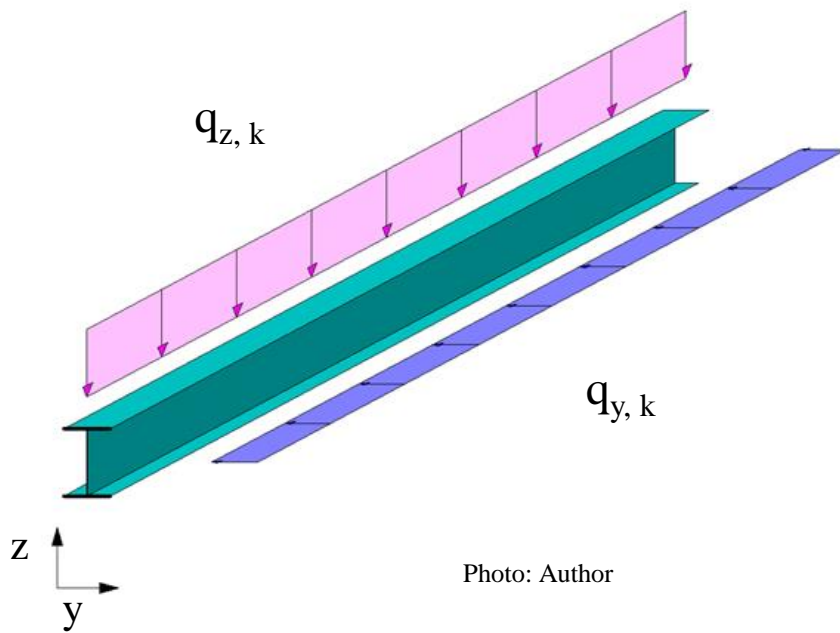

Photo: Author

$$M_{Ed, y} = q_z L^2 / 8 = 45,490 \text{ kNm}$$

$$M_{Ed, z} = q_y L^2 / 8 = 3,884 \text{ kNm}$$

$$V_{Ed, y} = q_y L / 2 = 2,589 \text{ kN}$$

$$V_{Ed, z} = q_z L / 2 = 30,993 \text{ kN}$$

## Resistances of cross-section:

$$M_{Rd,y} = f_y W_{pl,y} / \gamma_{M0} = 235 \text{ [MPa]} \cdot 628,4 \text{ [cm}^3\text{]} / 1,00 = 147,674 \text{ kNm}$$

$$M_{Rd,z} = f_y W_{pl,z} / \gamma_{M0} = 235 \text{ [MPa]} \cdot 125,2 \text{ [cm}^3\text{]} / 1,00 = 29,422 \text{ kNm}$$

$$V_{Rd,y} = f_y A_{v,y} / (\gamma_{M0} \sqrt{3}) = 235 \text{ [MPa]} \cdot 32,1 \text{ [cm}^2\text{]} / (1,732 \cdot 1,000) = 435,524 \text{ kN}$$

$$V_{Rd,z} = f_y A_{v,z} / (\gamma_{M0} \sqrt{3}) = 235 \text{ [MPa]} \cdot 21,3 \text{ [cm}^2\text{]} / (1,732 \cdot 1,000) = 288,993 \text{ kN}$$

## Checking resistances

$$E / R \leq 1,0$$

$$M_{Ed,y} / M_{Rd,y} \leq 1,0 \rightarrow 45,490 / 147,674 = 0,308 \quad \text{👍}$$

$$M_{Ed,z} / M_{Rd,z} \leq 1,0 \rightarrow 3,884 / 29,422 = 0,132 \quad \text{👍}$$

$$V_{Ed,y} / V_{Rd,y} \leq 1,0 \rightarrow 2,589 / 435,524 = 0,006 \quad \text{👍}$$

$$V_{Ed,z} / V_{Rd,z} \leq 1,0 \rightarrow 30,993 / 288,993 = 0,107 \quad \text{👍}$$

$$M_{Ed,y} = q_z L^2 / 8 = 45,490 \text{ kNm}$$

$$M_{Ed,z} = q_y L^2 / 8 = 3,884 \text{ kNm}$$

$$V_{Ed,y} = q_y L / 2 = 2,589 \text{ kN}$$

$$V_{Ed,z} = q_z L / 2 = 30,993 \text{ kN}$$

Bi-axial bending of I-beam (EN 1993-1-1 (6.41)):

$$(M_{Ed,y} / M_{Rd,y})^2 + M_{Ed,z} / M_{Rd,z} \leq 1,0 \rightarrow 0,308^2 + 0,132 = 0,227 \quad \text{👍}$$

### Checking stability:

Lateral buckling can occur as an effect of bending. For your range of design project you can assume (not completely correct), that sandwich panels protect purlins from instability.

### Checking deflections:

$$\Delta_y = 5 q_y L^4 / (384 E J_z) =$$

$$= 5 \cdot 0,144 \text{ [kN/m]} \cdot 6,0^4 \text{ [m}^4\text{]} / (384 \cdot 210 \text{ [GPa]} \cdot 603,8 \text{ [cm}^4\text{)}) = 1,9 \text{ mm}$$

$$\Delta_z = 5 q_z L^4 / (384 E J_y) =$$

$$= 5 \cdot 1,745 \text{ [kN/m]} \cdot 6,0^4 \text{ [m}^4\text{]} / (384 \cdot 210 \text{ [GPa]} \cdot 8356 \text{ [cm}^4\text{)}) = 1,7 \text{ mm}$$

$$\Delta = \sqrt{(\Delta_y^2 + \Delta_z^2)} = 2,5 \text{ mm}$$

$$\Delta_{acc} = \text{EN 1993-1-1 N.A. 22} = L / 200 = 30 \text{ mm}$$

$$\Delta / \Delta_{acc} = 0,085 \quad \text{👍}$$

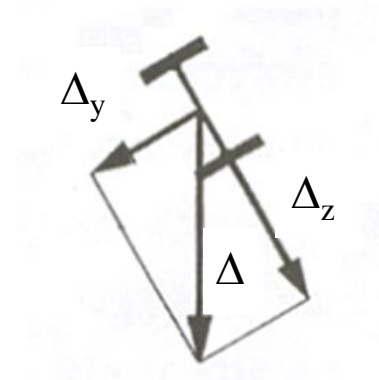

Photo: Author

→ Des #1 / 42

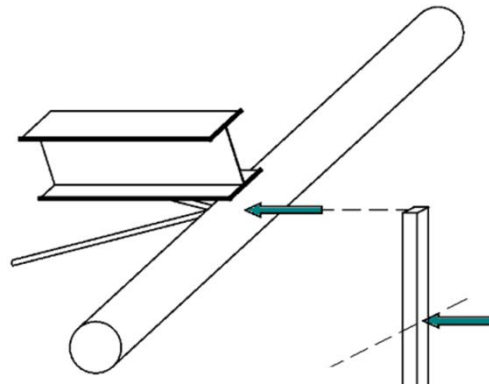

Photo: Author

Axial force occurs in purlins as a result of interaction between purlins and bracings (#Des1 / 24). More information will be presented on Lecture #8 and #10.

If you use 3D computer full model of structure, you get immediately full information about cross-sectional forces in purlins ( $N_{Ed}$ ,  $M_{Ed, y}$ ,  $M_{Ed, z}$ ).

Otherwise (2D), you must calculate purlins in two steps:

- for bi-axial bending;
- (after analysis of bracings) for bi-axial bending and axial force.

For this situations, effort in first step should be equal 0,8 ~ 0,9 to ensure „space” for additional effort from axial force.

## Conclusions:

E	M <sub>Ed, y</sub>	M <sub>Ed, z</sub>	V <sub>Ed, y</sub>	V <sub>Ed, z</sub>	M <sub>Ed, y</sub> + M <sub>Ed, z</sub>	Lateral buckling	Δ
E / R	0,308	0,132	0,006	0,107	0,227	Not checked in Your range of project	0,085

1. Each results satisfy fundamental requirement  $E / R \leq 1,0$ . But the highest value for analysed case (0,308) is far from upper limit (1,000) – this means, cross-section is too big (too expensive) for situation. It's somethink like situation: total cost of structure = 10 M€, but only 3,080 M€ is justified, the rest (6,920 M€) is the result of the designer's inability.

You should check smaller one I-beam (IPE 270? IPE 240?). You no need recalculated values of loads: influence of change dead-weight of purlin for total loads (snow, wind...) is negligible.

2. This purlin will be recalculated after analysis of roof bracings. Axial force in purlin occurs as the effect of coopreation bracings-purlins. Max effort could be bigger that now. Because of this, efforts for smaller one purlin (IPE 270? IPE 240?) should be:

- $E / R \leq 1,0$  for Δ;
- $E / R \leq 0,8$  all the rest conditions.

### III<sup>rd</sup> example of calculations – truss members

According to #t /10, few cases of combination of actions must be applied to structure.

For vertical downward actions (dead-weight, wind pressure, snow, imposed load) top cord will be under compression and bottom under tension.

But there is possible, than for big value of wind suction, opposite complex of cross-sectional forces (top – tension, bottom-compression) occurs.

(New complex of data)

Chord	Max tension [kN]	Max compression [kN]	Cross-section
Top	-45,987 (w↑)	328,322 (w↓)	Hot-rolled CHS 159,0x8,0
Bottom	-335,621 (w↓)	43,181 (w↑)	

Verification:

$$|\text{top tension}| \approx |\text{bottom compression}| \quad (\text{w}\uparrow)$$

$$|\text{top compression}| \approx |\text{bottom tension}| \quad (\text{w}\downarrow)$$

# Geometry of structure

Photo: Author

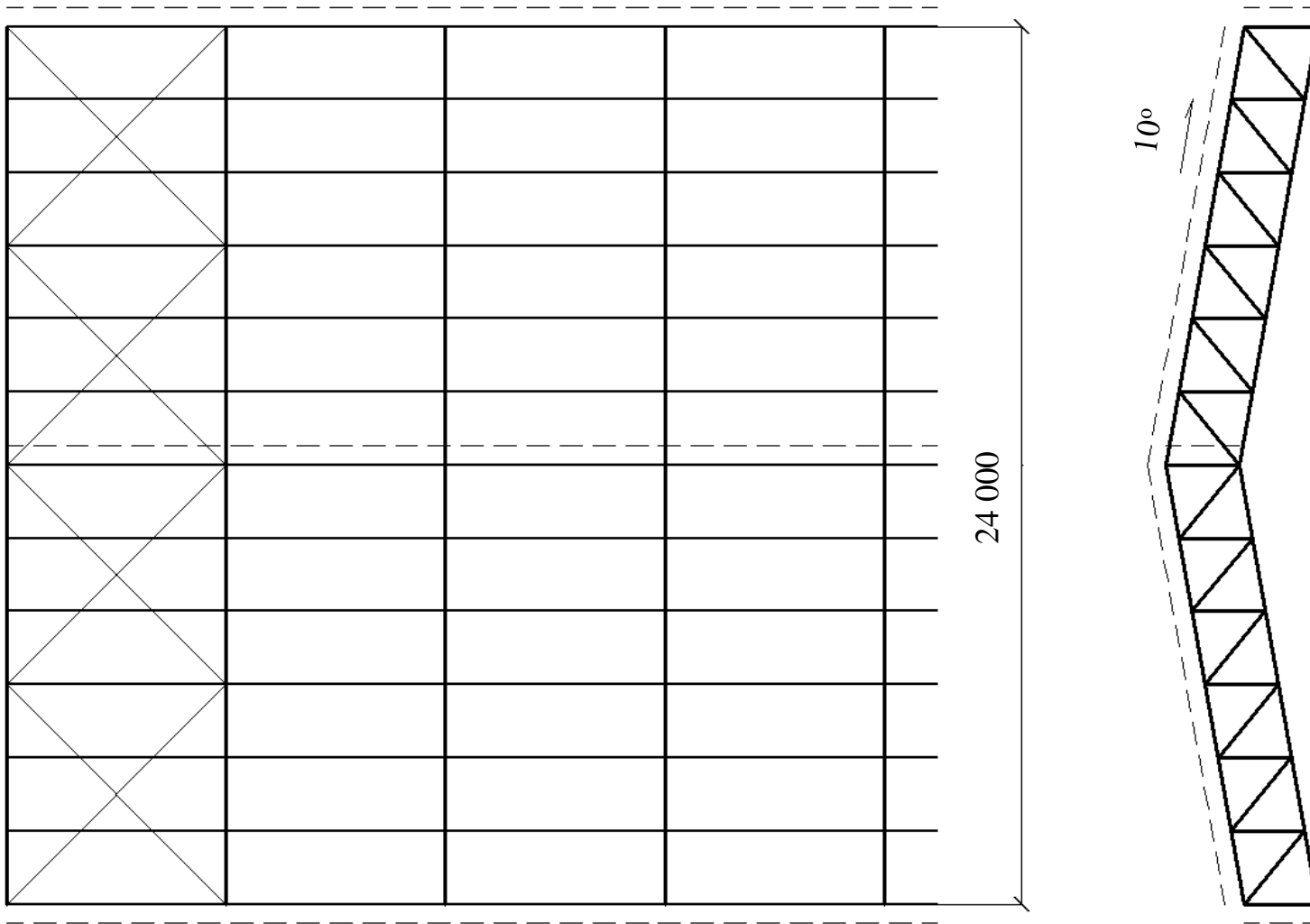

# Geometry of structure

Photo: Author

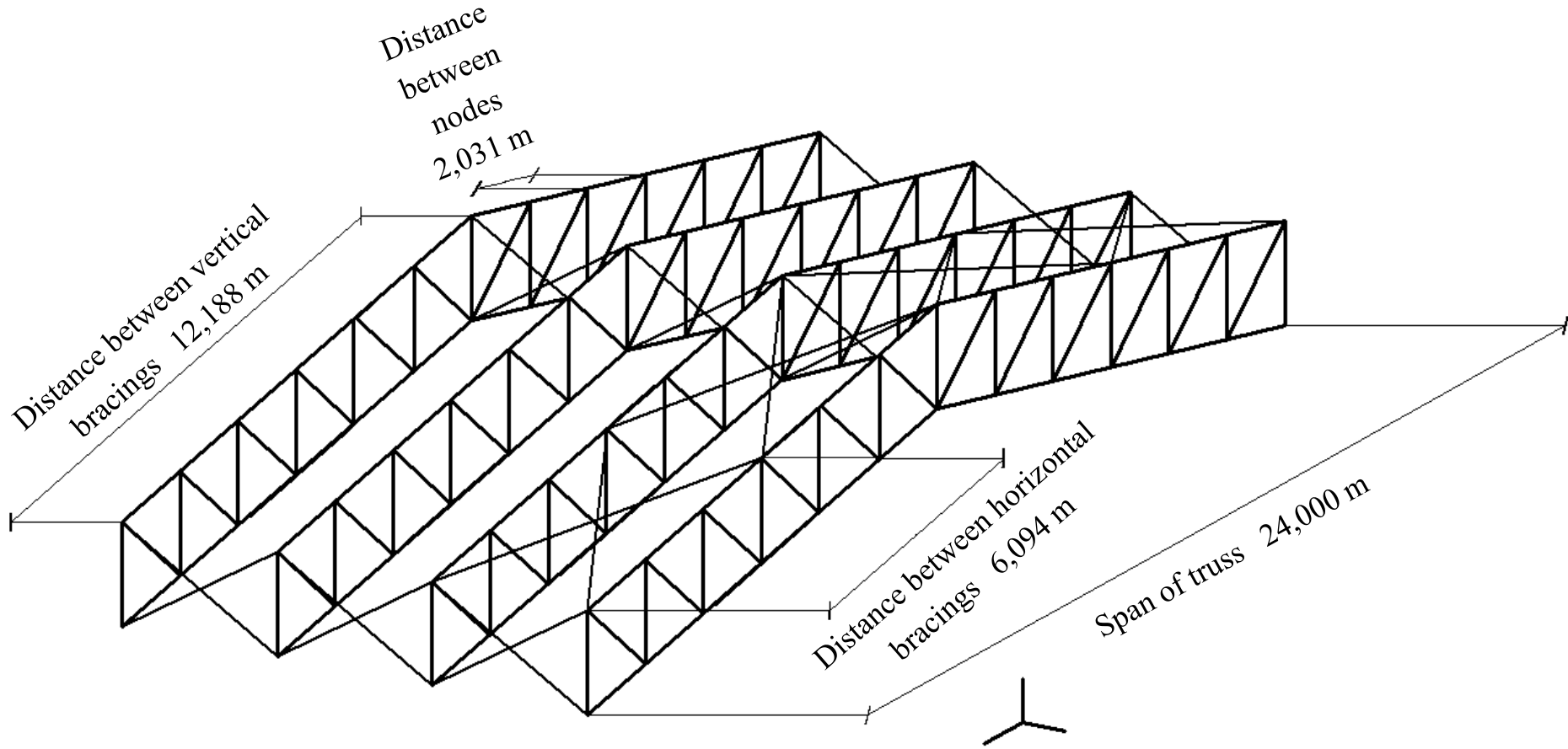

Hot-rolled CHS 159,0x8,0 (159,0 mm diameter, 8,0 mm thickness):

$$A = 38,00 \text{ cm}^2$$

$$J_y = J_z = 1\,085,00 \text{ cm}^4$$

$$i_y = i_z = 5,35 \text{ cm}$$

$$S\ 235 \rightarrow f_y = 235 \text{ MPa}$$

$$\varepsilon = \sqrt{(235 / f_y)} = 1,0$$

S 235 + CHS hot rolled cross-section  $\rightarrow$  buckling curve a  $\rightarrow \alpha = 0,21$

(EN 1993-1-1 tab. 6.1, 6.2)

## Resistances of cross-section:

$$N_{Rd} = f_y A / \gamma_{M0} = 235 \text{ [MPa]} \cdot 38,00 \text{ [cm}^2\text{]} / 1,00 = 893,000 \text{ kN}$$

## Checking resistances

$$E / R \leq 1,0$$

$$N_{Ed, \text{ top, comp}} / N_{Rd} \leq 1,0 \rightarrow 328,322 / 893,000 = 0,368 \quad \text{👍}$$

$$N_{Ed, \text{ top, tens}} / N_{Rd} \leq 1,0 \rightarrow 45,957 / 893,000 = 0,051 \quad \text{👍}$$

$$N_{Ed, \text{ bott, comp}} / N_{Rd} \leq 1,0 \rightarrow 43,181 / 893,000 = 0,048 \quad \text{👍}$$

$$N_{Ed, \text{ bott, tens}} / N_{Rd} \leq 1,0 \rightarrow 335,621 / 893,000 = 0,376 \quad \text{👍}$$

Distance between supports for truss members is depend on plane of analysis and part of structure. For web members, in both planes distance between supports = distance between nodes.

Flexural buckling of chords:

→ Des #1 / 53

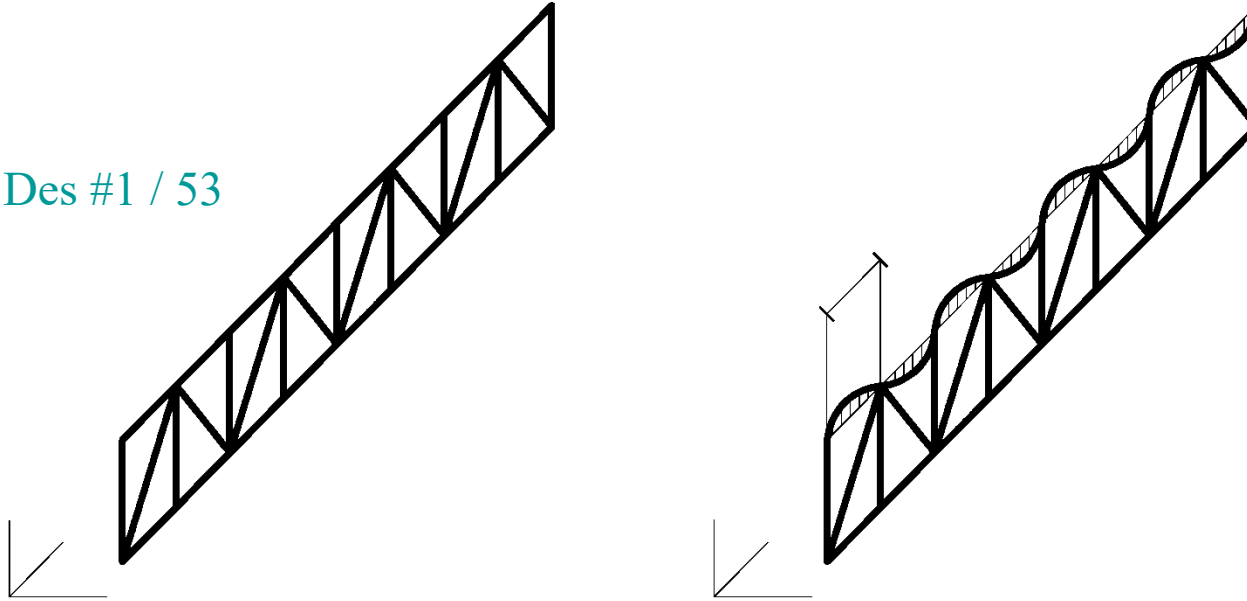

Photo: Author

Top chords in compression; buckling in plane: distance between supports = distance between nodes

# Flexural buckling of chords:

→ Des #1 / 54

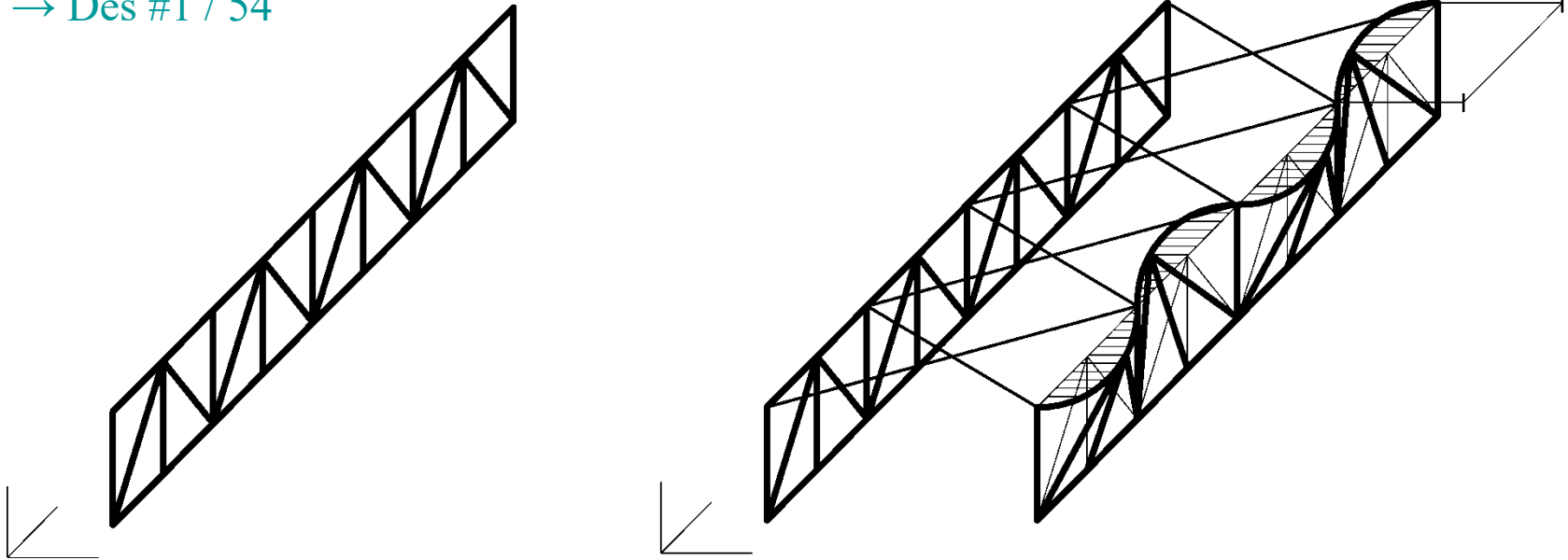

Photo: Author

Top chords in compression; buckling out of plane: distance between supports = distance between horizontal bracings

## Flexural buckling of chords:

→ Des #1 / 55

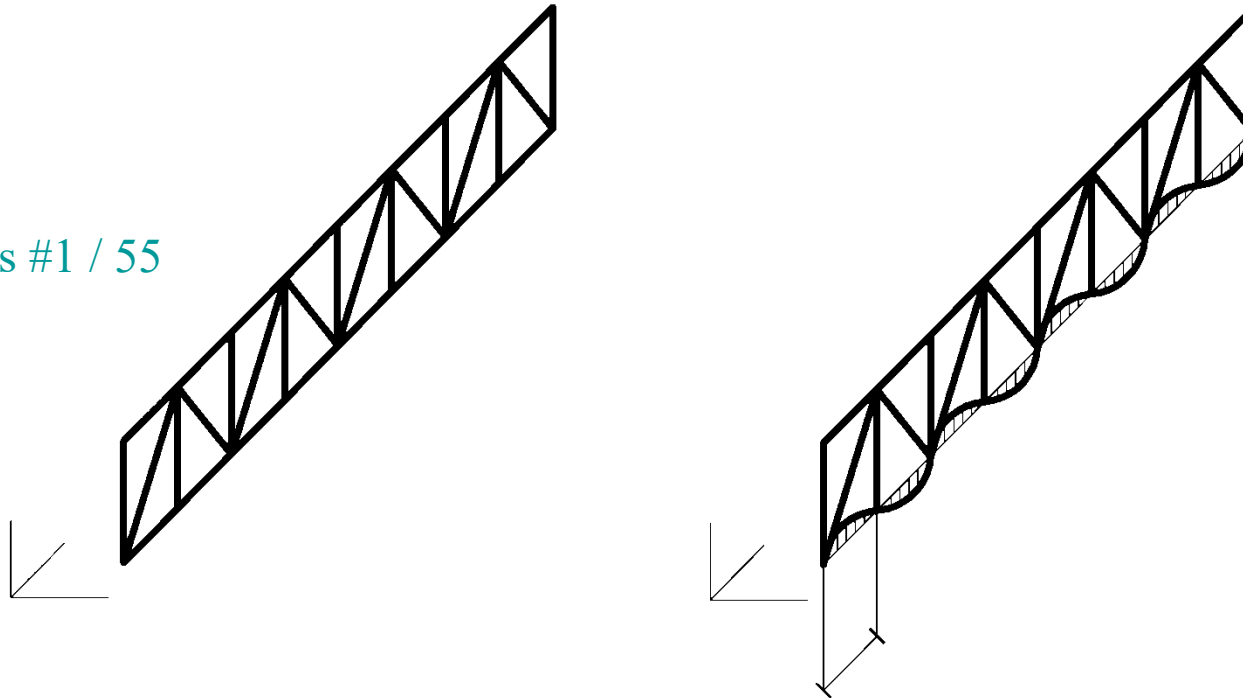

Photo: Author

Bottom chords in compression; buckling in plane: distance between supports = distance between nodes

# Flexural buckling of chords:

→ Des #1 / 56

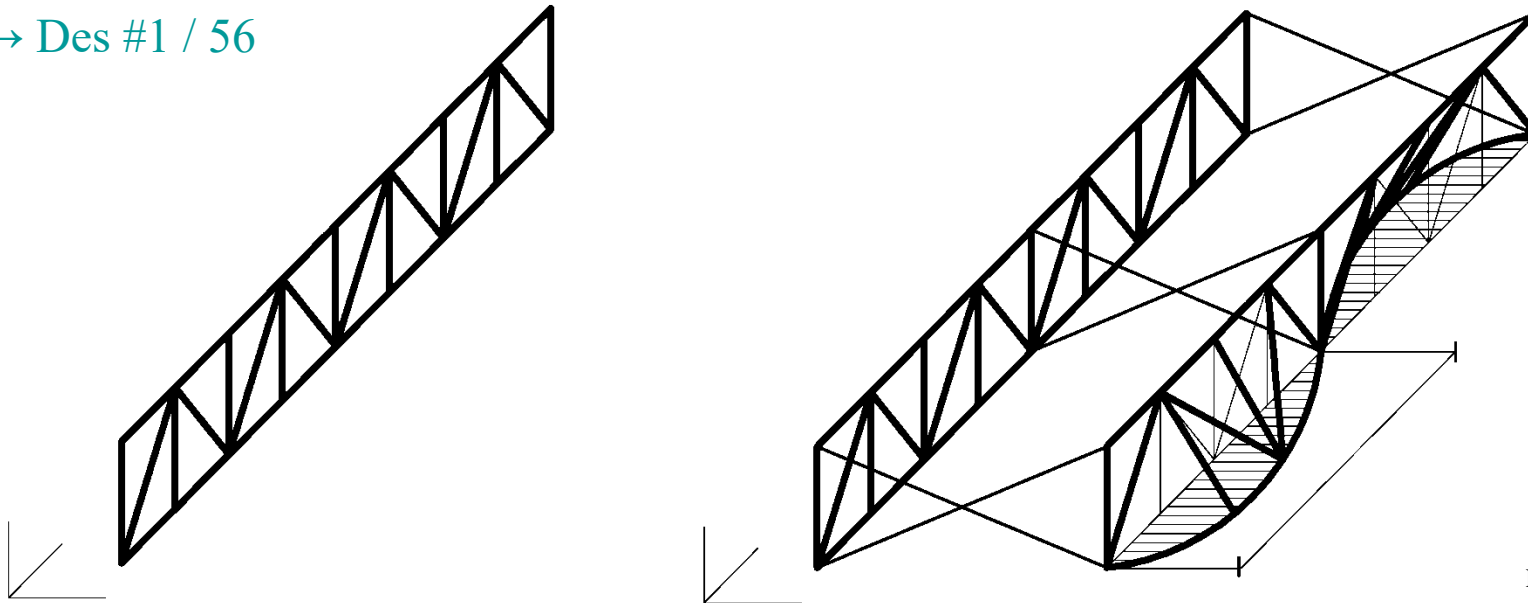

Photo: Author

Bottom chords in compression; buckling out of plane: distance between supports = distance between vertical bracings

Eurocode gives critical length factor („type of support”) in dependence of type of cross-sections:

→ Des #1 / 57  Chord	In plane	I H	0,9
		RHS CHS	0,9
	Out of plane	I H	1,0
		RHS CHS	0,9
Truss bracing	In plane	RHS CHS	0,9 (0,75)
	Out of plane	RHS CHS	1,0 (0,75)

Value in brackets: (chords parallel,  $d_{\text{truss bracing}} / d_{\text{chord}} < 0,6$ )

# Critical length

Photo: Author

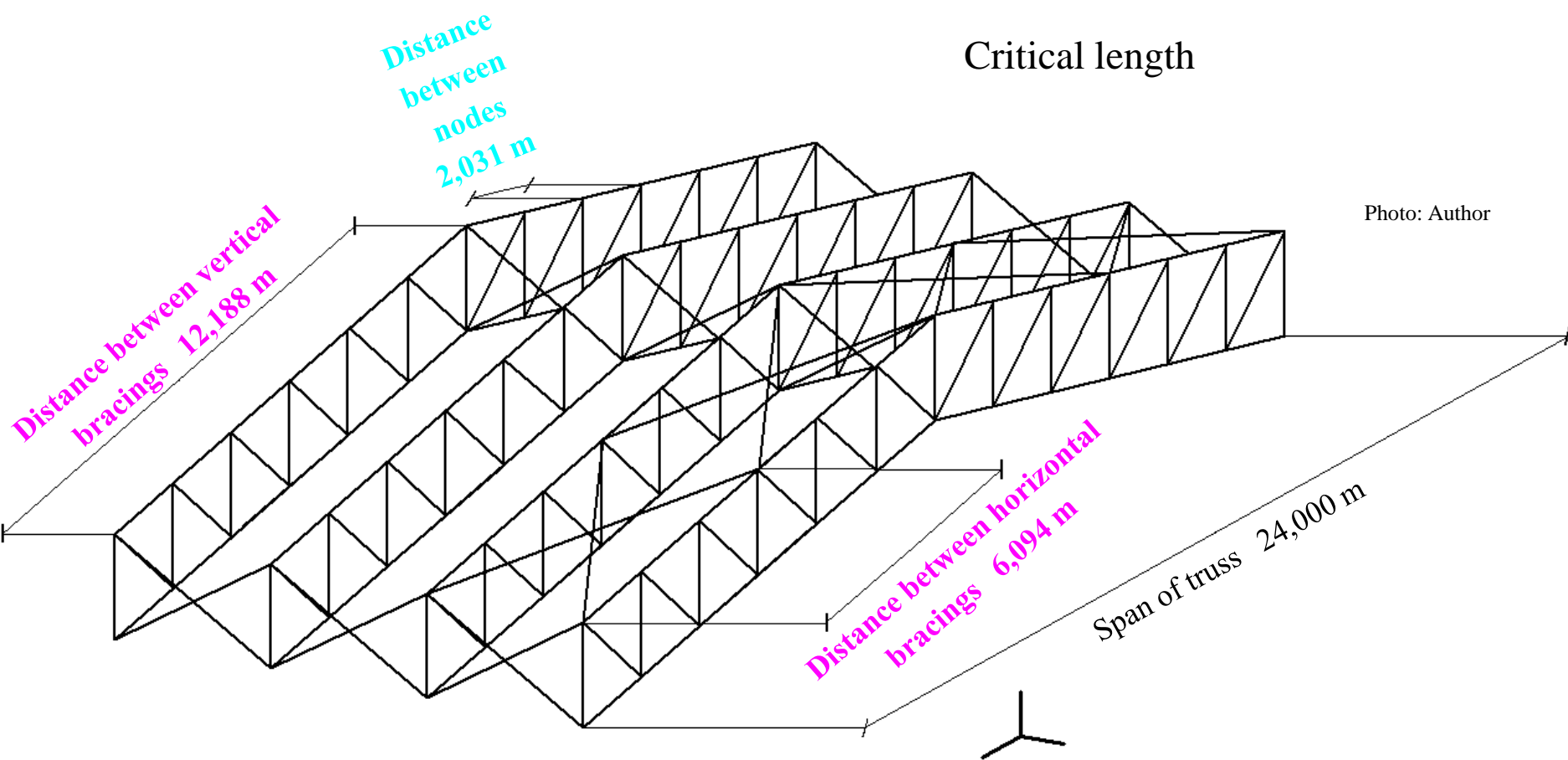

Chord	$l_{cr}$ in plane [m]	$l_{cr}$ out of plane [m]
Top	$0,9 \cdot 2,031 = 1,828$	$0,9 \cdot 6,094 = 5,485$
Bottom	$0,9 \cdot 2,031 = 1,828$	$0,9 \cdot 12,188 = 10,969$

Checking stability (EN 1993-1-1 6.3.1.2):

$$\lambda = (l_{cr} / i) / (93,9 \varepsilon)$$

$$\varepsilon = \sqrt{(235 / f_y)}$$

$$\Phi = [1 + \alpha (\lambda - 0,2) + \lambda^2] / 2$$

$\alpha$  - factor for buckling curve according to EN 1993-1-1 tab. 6.1, 6.2

$$\chi = \min \{1 / [\Phi + \sqrt{(\Phi^2 - \lambda^2)}] ; 1,0\}$$

**$\chi$  can't be greater than 1,0**

Requirement:

$$N_{Ed} / (\chi N_{Rd}) \leq 1,0$$

Chord	$l_{cr} / i$ in plane	$l_{cr} / i$ out of plane
Top	34,168	102,516
Bottom	34,168	205,032

Recommendation:  $l_{cr} / i \leq 250,0$  👍

Chord	$\lambda$ in plane	$\lambda$ out of plane
Top	0,364	1,092
Bottom	0,364	2,184

S 235 + CHS hot rolled cross-section → buckling curve a →  $\alpha = 0,21$   
(EN 1993-1-1 tab. 6.1, 6.2)

Chord	$\Phi$ in plane	$\Phi$ out of plane
Top	0,583	1,190
Bottom	0,583	3,093

Chord	$\chi$ in plane	$\chi$ out of plane
Top	0,963	0,670
Bottom	0,963	0,189

**Instability: compressive forces only are taken into consideration**

Chord	Max tension [kN]	Max compression [kN]	
		$E / R_{cr}$ in plane	$E / R_{cr}$ out of plane
Top		$328,322 / (893,000 \cdot 0,963) =$ $= 0,382$	$328,322 / (893,000 \cdot 0,670) =$ $= 0,549$
Bottom		$43,181 / (893,000 \cdot 0,963) =$ $= 0,050$	$43,181 / (893,000 \cdot 0,189) =$ $= 0,256$

## Checking deflection:

Max vertical deformation under loads (FEM calculation): 13 mm

$$\Delta_{\text{acc}} = \text{EN 1993-1-1 N.A. 22} = L / 250 = 96 \text{ mm}$$

$$\Delta / \Delta_{\text{acc}} = 0,135 \quad \text{👍}$$

Conclusions:

Resistance:

Chord	E / R tension	E / R compression
Top	0,051	0,368
Bottom	0,376	0,048

Stability (compressive force only):

Chord	Tension	E / R <sub>cr</sub> compression, flexural buckling in plane	E / R <sub>cr</sub> compression, flexural buckling out of plane
Top		0,382	<b>0,549</b>
Bottom		0,050	0,256

Deflection: 0,135 👍

Max effort < 55% → lighter cross-section should be applied

# IV<sup>th</sup> example of calculations – roof bracing

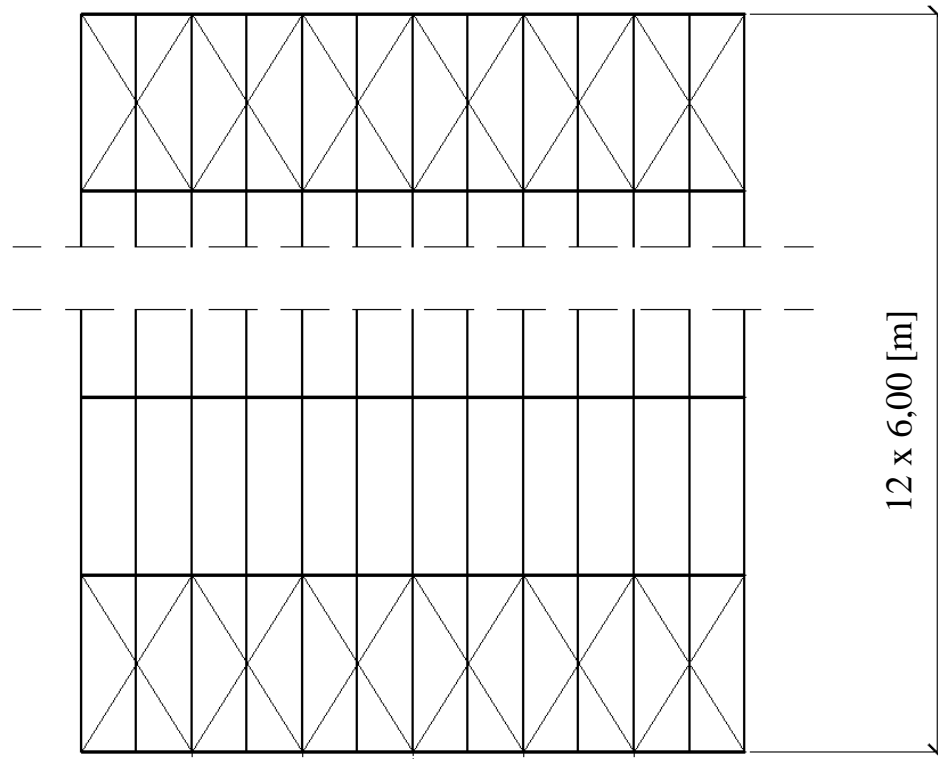

12 x 6,00 [m]

Photo: Author

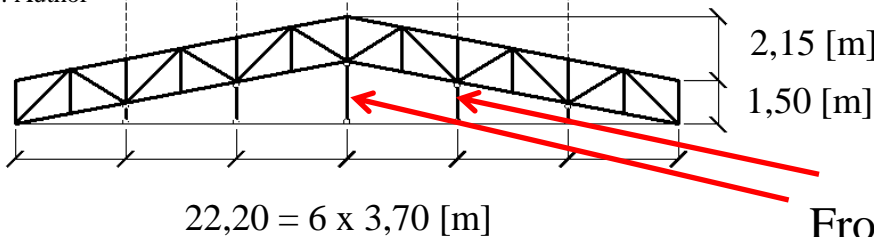

Front wall columns (on first and last truss only)

(New complex of data)

Chord	Max tension [kN]	Max compression [kN]	Cross-section
Top	-55,112	302,157	CHS 108x10
Bottom	-304,853	52,789	

Purlins IPE 270

S 235 →  $f_y = 235$  MPa

Wind load:

- winward front wall 0,8 kPa
- roof slope -0,7 kPa
- side walls -0,6 kPa
- leeward front wall -0,5 kPa

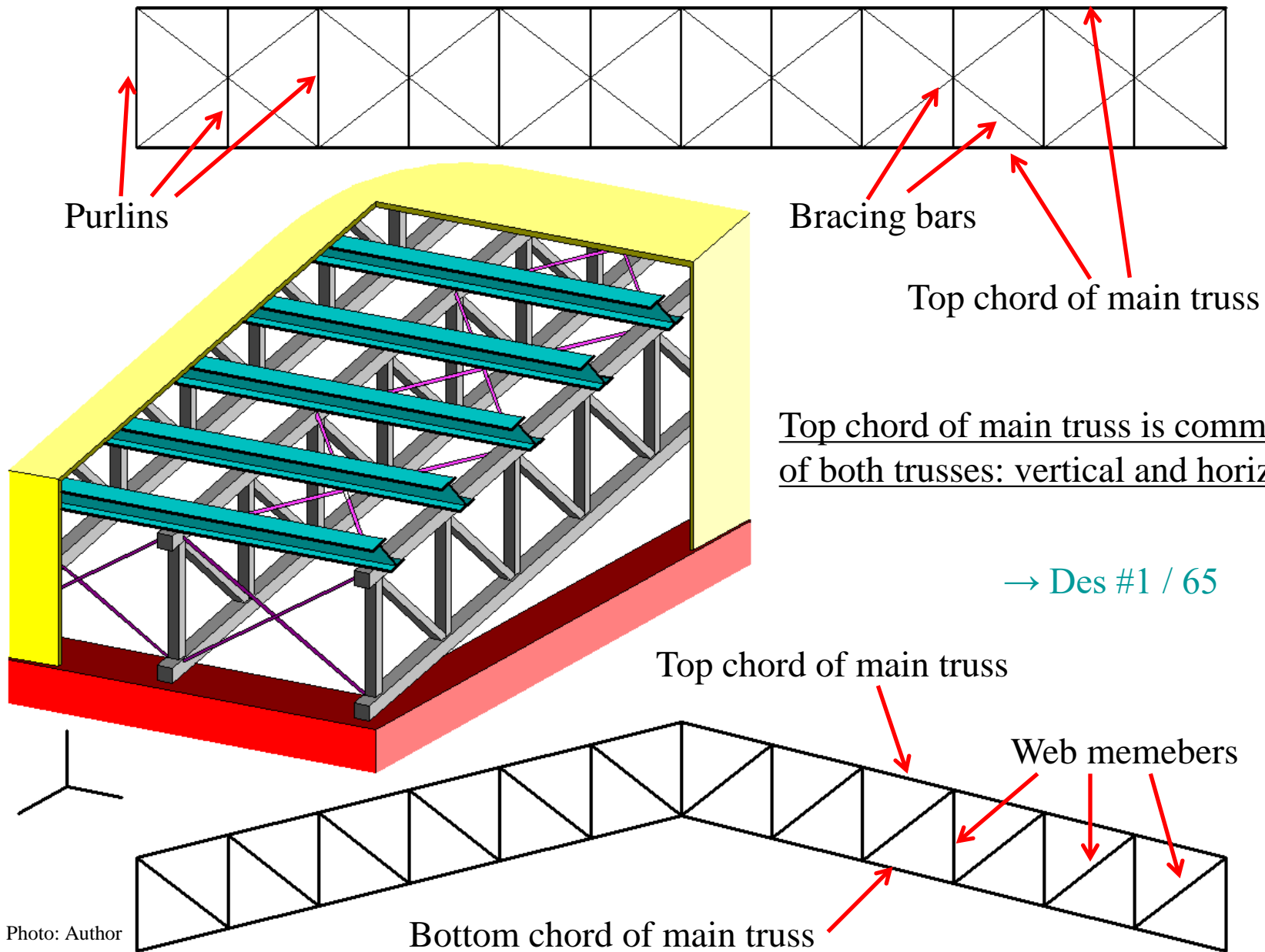

# Cooperation purlins-bracings-girder

Common point for purlin, horizontal bracings and front column

→ Des #1 / 24

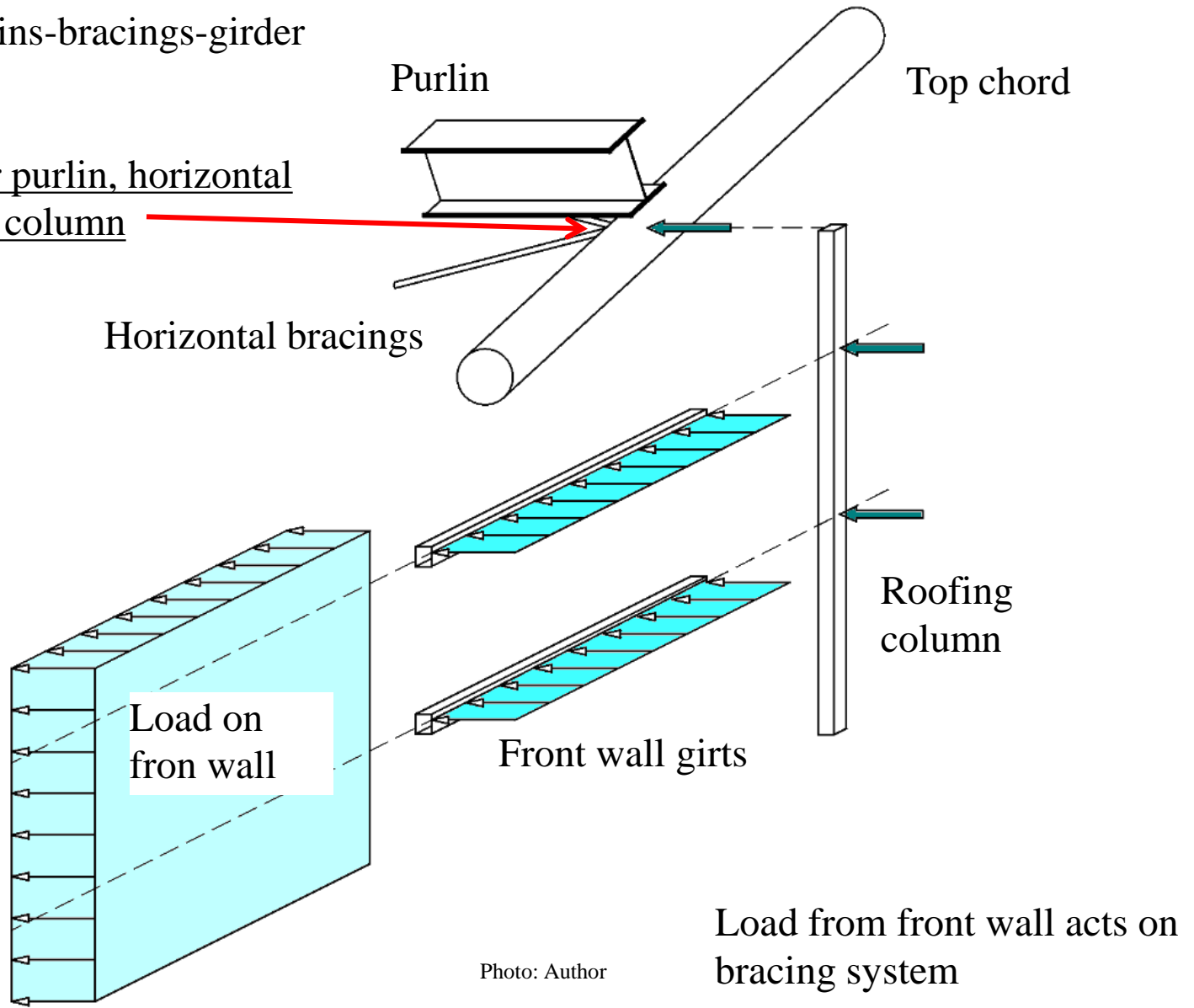

Photo: Author

Static analysis of vertical truss



Forces in top and bottom chords of vertical truss



Checking resistance and stability members of vertical truss



Forces in chords of horizontal truss – this means additional value of force in top chord of vertical truss



Checking resistance and stability members of horizontal truss



New value of force in top chord of vertical truss



Once again checking resistance and stability top chord of vertical truss

→ Des #1 / 67

The forces applied to the horizontal bracing depend on the compression forces in the upper chord of the vertical truss. At the same time, the spatial cooperation of all elements results in additional forces appearing twice - in the purlin (→ #Des1 / 42) and in the upper chord of the horizontal truss (→ #Des1 / 66) - coming from the cooperation of braces with these elements.

This problem can be solved at the stage of the numerical model in two ways:

- accurately in a 3D model;
- approximately in a flat 2D model.

Way of calculation - 2D vs. 3D - is very important for algorithm.

→ Des #1 / 68

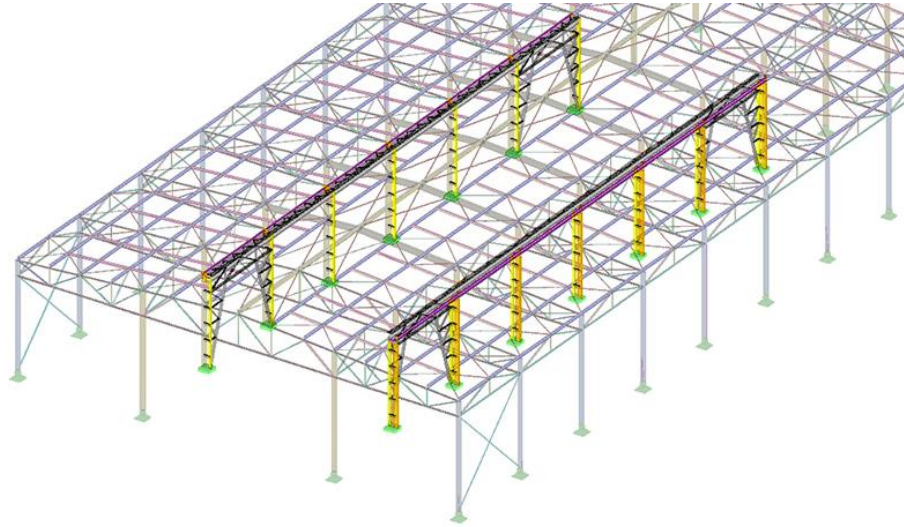

Photo: mesilo.pl

3D model in FEM calculations: we have full information about cooperation between trusses, purlins and bracing bars right away. Calculation is made in two steps:

- Initial calculation: dead weight, climatic actions, live loads etc.
- Equivalent forces: from imperfections of trusses and from prevention of instability of trusses. Values of these forces are calculated based on forces in trusses after initial calculations.

Final effect: forces in chords from initial calculations and equivalent forces is final result of static calculations.

2D model (method of equivalent flat frames) is much more complicated:

Purlin: **bi-axial bending**

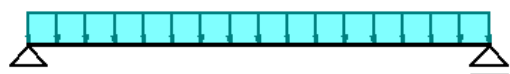

Flat frame: **forces from purlins**

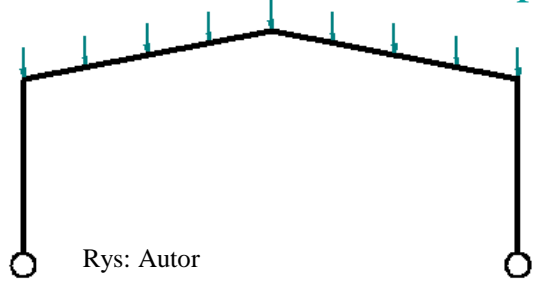

Roof bracings:  
horizontal truss

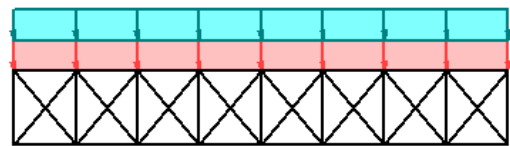

Wind action  
Equivalent forces from  
instability and imperfection

Cooperation frame-bracings:  
additional forces in purlins,  
additional forces in frame.

→ Des #1 / 69

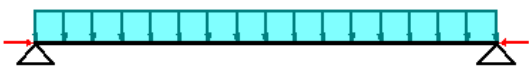

Purlin: **bi-axial bending** +  
**compressive axial force**  
(recalculation)

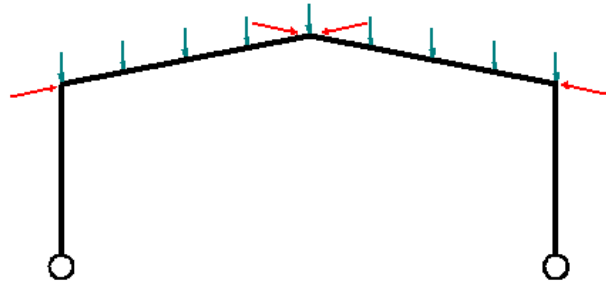

Frame: **additional axial forces**  
from cooperation with  
bracings (recalculation)

Example is made for 2D model.

$$S\ 235 \rightarrow f_y = 235\ \text{MPa}$$

$$\varepsilon = \sqrt{(235 / f_y)} = 1,0$$

S 235 + CHS hot rolled →  
buckling curve a →  $\alpha = 0,21$   
(EN 1993-1-1 tab. 6.1, 6.2)

Top chord: hot-rolled CHS 108x10 (108 mm diameter, 10 mm thickness):

$$A = 30,8\ \text{cm}^2$$

$$J_y = J_z = 373,0\ \text{cm}^4$$

$$i_y = i_z = 3,48\ \text{cm}$$

Wind pressure and wind suction of both front walls are beared by roof bracings.

Roof bracings prevent trusses chords from buckling → buckling equivalent forces from chords act on bracings.

Trusses chords are not ideal straight (imperfection) → imperfection equivalent forces act on roof bracings.

# Static model

Recommendation for bracing bars: round bar  $\phi 25$  (Des #1 / 70).

Round bars are very flexible and lost their stability under very very small value of compressive force. So, only bars under tension will cooperate with structure.

Photo: Author

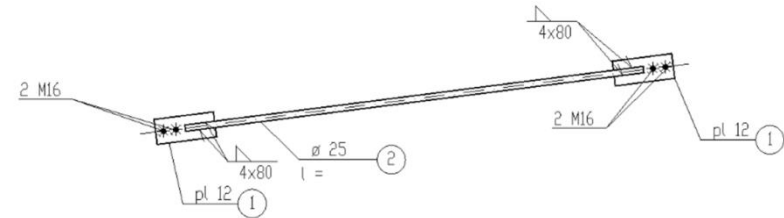

Photo: A. Biegus, Przyczyny przedawaryjnego stanu technicznego płatwi hali stalowej, Budownictwo i Architektura 12 / 2013, 173-180

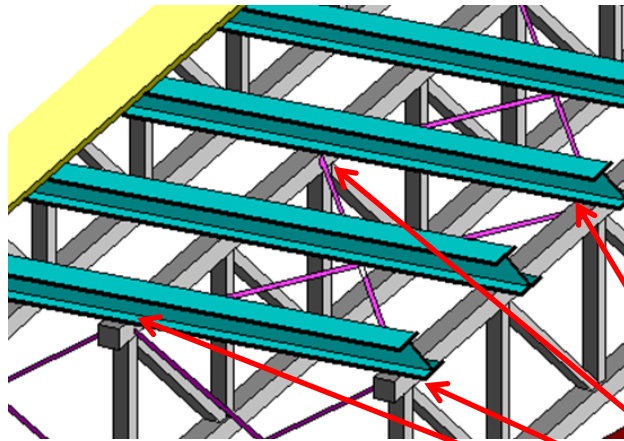
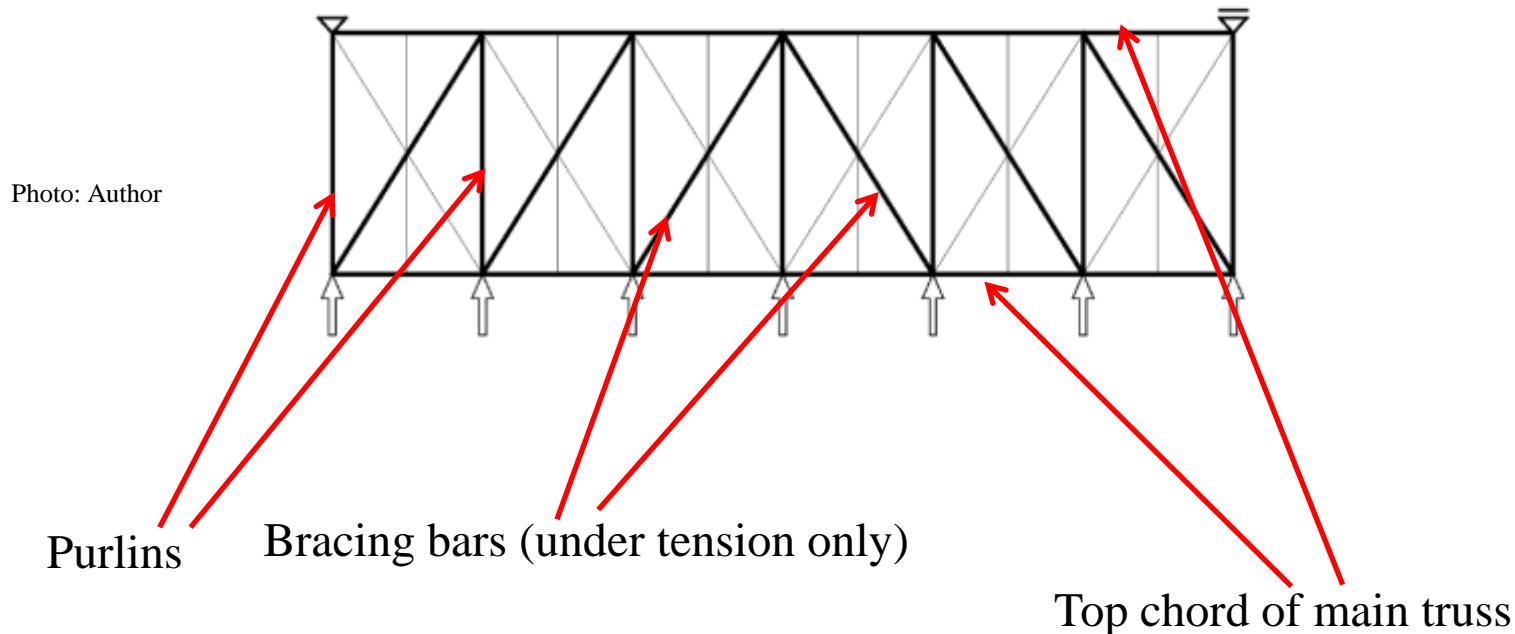

Photo: Author

Bracings bars are installed **between** top chords of vertical truss. Purlins are **over** top chords of vertical truss. Cooperation between bracing bars and purlins is possible for only these purlins, which have **common points** with bracing bars.

Bracing bars under compression are not taken into numeric model.  
Only every second purlin (cooperated with bracing bars) is taken into numeric model.



Three various types of actions must be analysed.

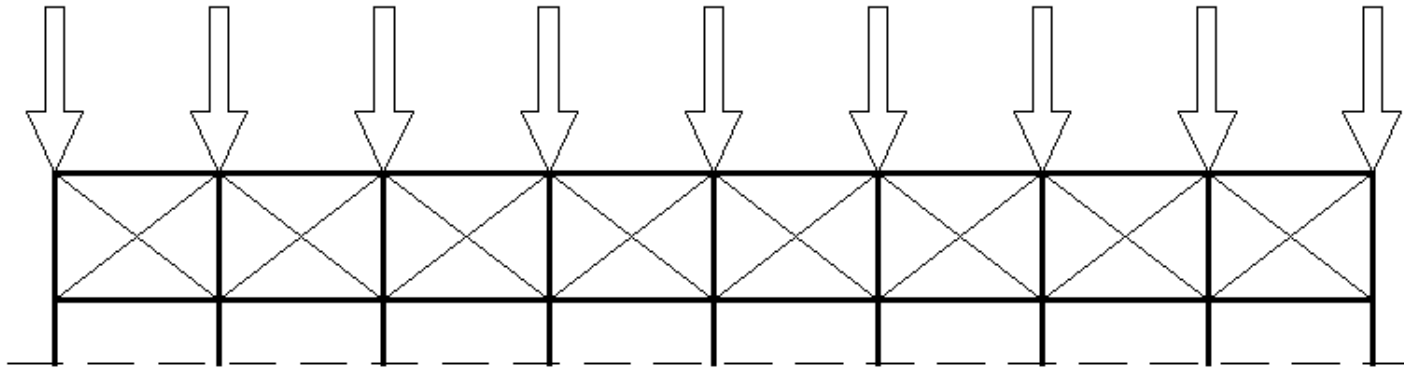

Photo: Author

1. Wind action (pressure on windward wall + suction on leeward wall + wind friction).  
Load depends on area of front wall and wind pressure.

Wind action is sum of:

- wind pressure on on winward wall = wind load · part area of front wall;
- wind friction on roof slope = wind action · friction factor · part area of roof slope +  
+ wind action · friction factor · part area of side walls;
- wind suction on leeward wall = wind load · part area of front wall;

side walls:

- „dead part”, turbulent wind, no friction;
- top part, load applicated to roof bracings – „friction part”;
- bottom part, load applicated to truss bases;

roof slope:

- „dead part”, turbulent wind, no friction;
- „friction part”;

Photo: Author

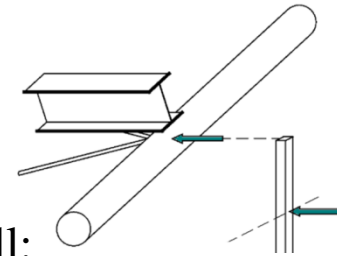

winward wall:

- top part, load applicated to roof bracings;
- bottom part, load applicated to front wall column bases;

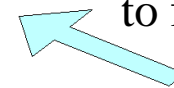
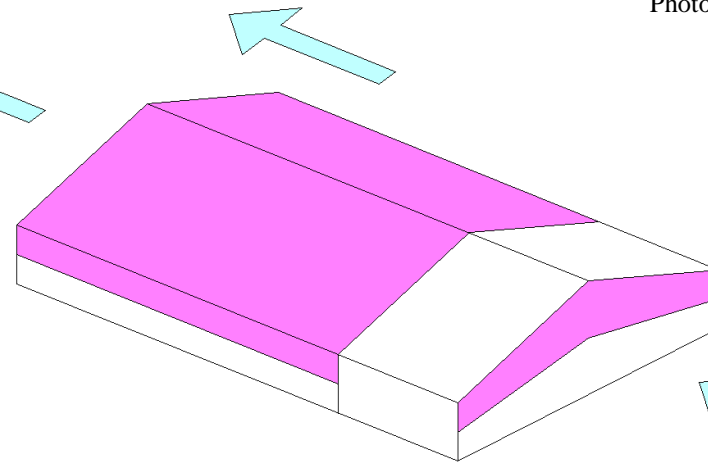
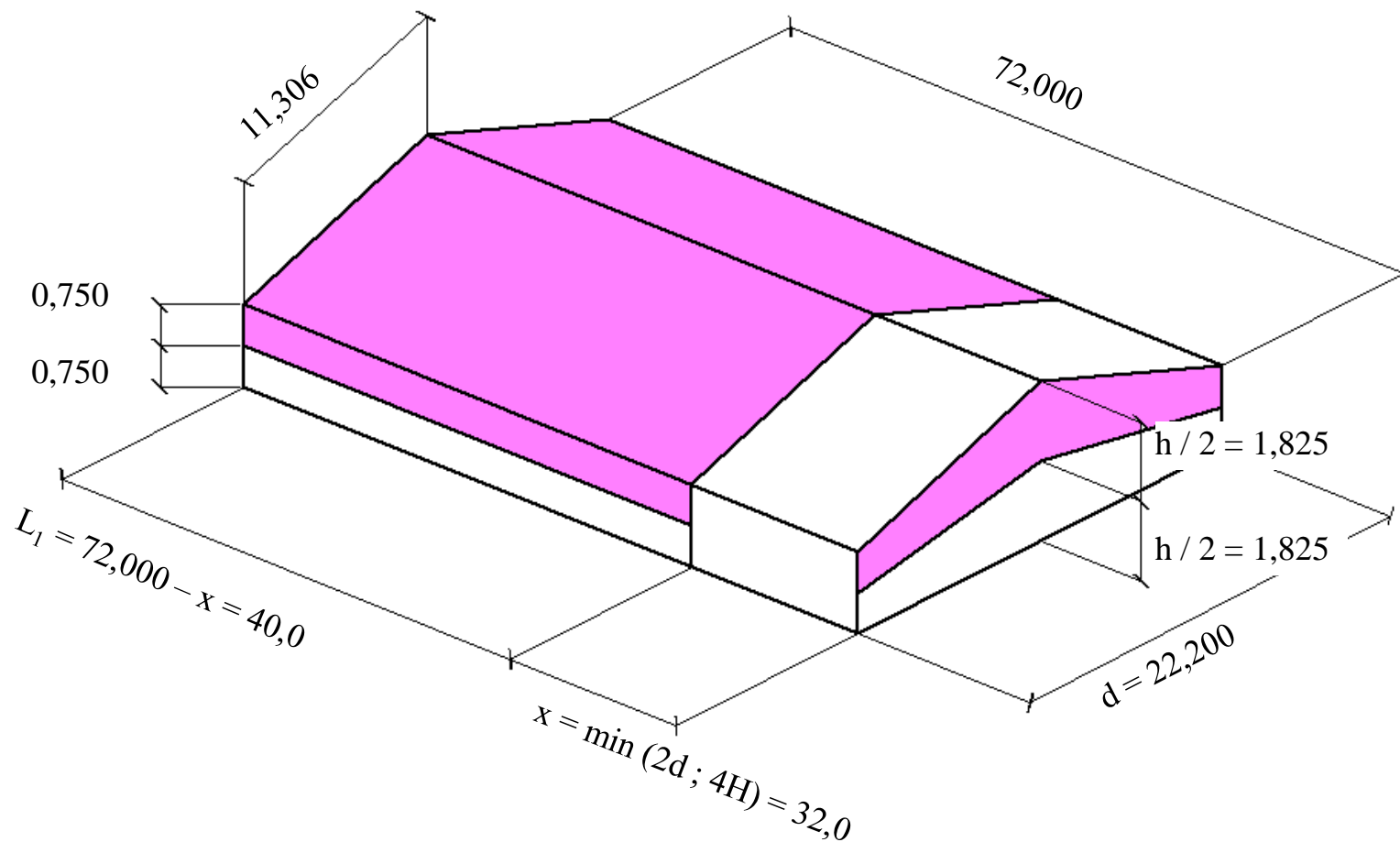

Photo: Author



leeward wall:

- top part, load applicated to roof bracings;
- bottom part, load applicated to front wall column bases;



Geometry of turbulent area (length  $x$ ) according to EN 1991-1-4 7.5 ( $h$  – height of truss = 3,65 m,  $H$  – total height of building: wall + truss = 8,0 m)

Friction coefficients: EN 1991-1-4 tab 7.10

Surface	$c_{fr}$
<b>steel, smooth concrete</b>	<b>0,01</b>
rough concrete, tar-boards	0,02
ripples, ribs, folds	0,04

Winward front wall **active part**: approximation, half of total area of front wall = 28,583 m<sup>2</sup>

Roof slope **active part**: 1 297,929 m<sup>2</sup>

Side walls **active part**: 60,000 m<sup>2</sup>

Leeward front wall **active part**: approximation, half of total area of front wall = 28,583 m<sup>2</sup>

$$\begin{aligned} \text{Wind total} &= A_{\text{wiward}} \cdot q_{w, \text{wiward}} + A_{\text{slope}} \cdot q_{w, \text{slope}} \cdot c_{fr} + A_{\text{side}} \cdot q_{w, \text{side}} \cdot c_{fr} + A_{\text{leeward}} \cdot q_{w, \text{leeward}} = \\ &= 28,583 \cdot 0,8 + 1\,297,929 \cdot 0,7 \cdot 0,01 + 60,000 \cdot 0,6 \cdot 0,01 + 28,583 \cdot 0,5 = 46,603 \text{ kN} \end{aligned}$$

Total force is divided between nodes of horizontal truss; simplification: even division.

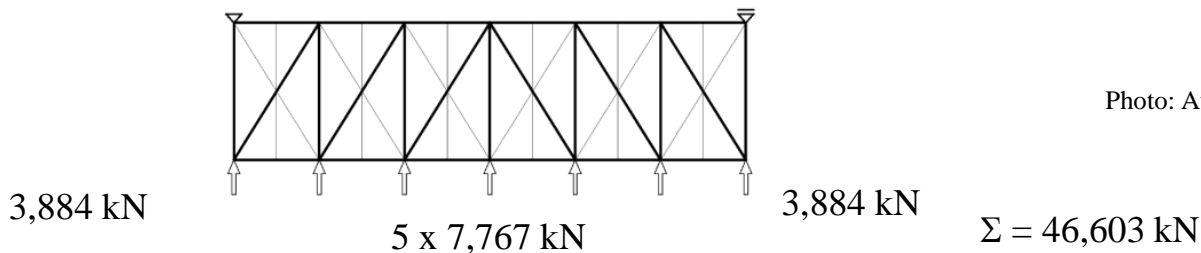

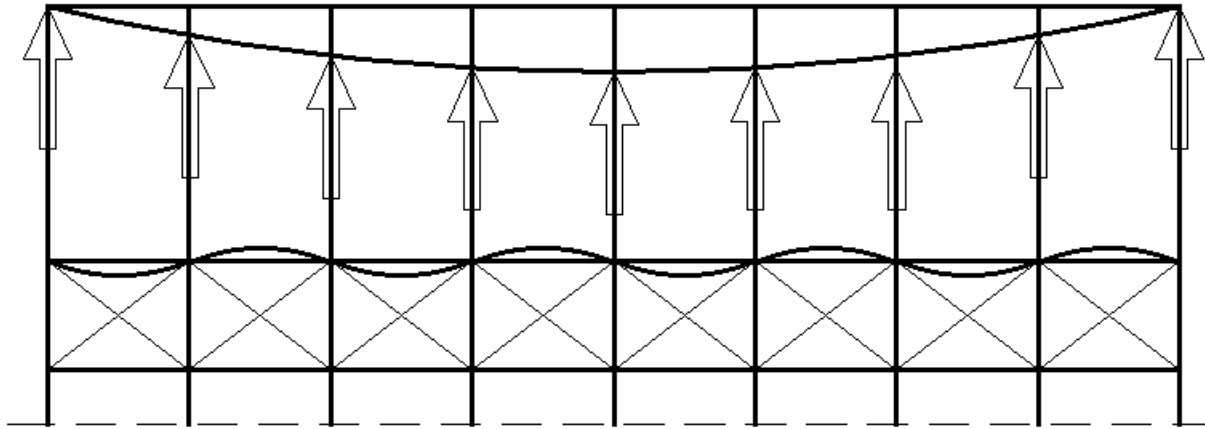
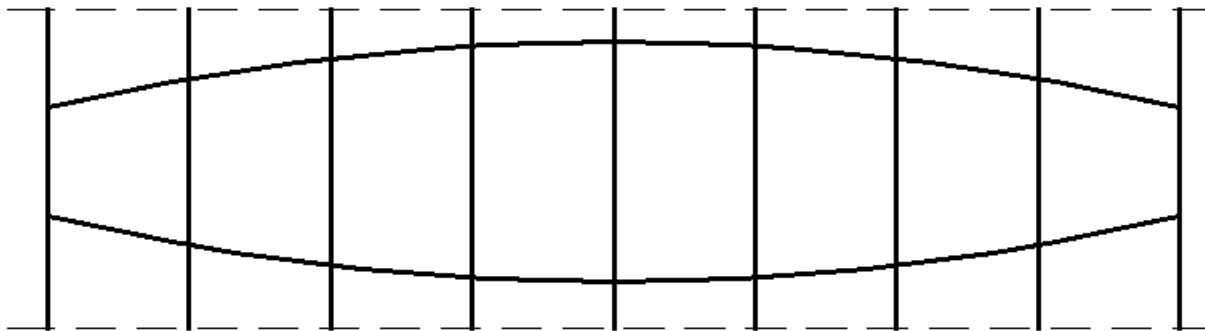

Photo: Author

→ Des #1 / 61



## 2. Instability of roof girders.

Bracing prevent roof girder from instability out of truss plane.

Without them, buckling of girder occurs on total length. Bracings act as complex of forces, make girder more straight. These forces – as reaction – must be applied to bracings. Value of these forces is **equivalent load**, in proportion to compressive force in girder.

Girders lose stability randolmy, in left or right direction. Total effect for entire roof is not:  
 (single effect) · (number of girders m)  
 but: (single effect) · (reduction factor  $\alpha_m$ ).

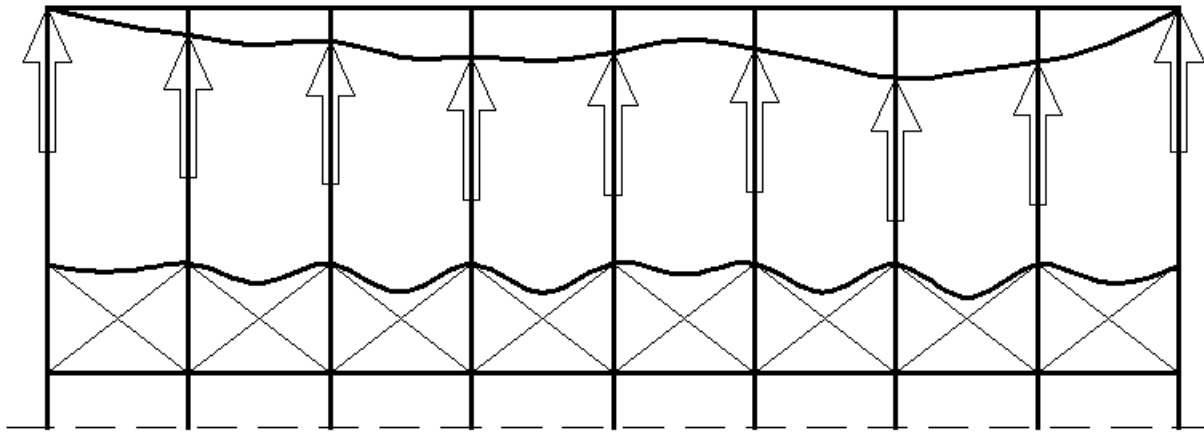
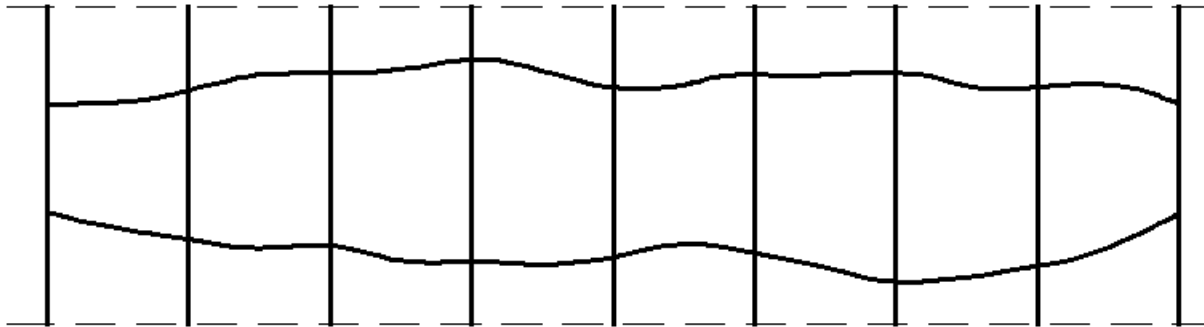

Photo: Author

→ Des #1 / 62

### 3. Imperfections of roof girders.

Roof girders are not perfectly straight. Bracings act as complex of forces, make girder more straight. These forces – as reaction – must be applied to bracings. Value of these forces is **equivalent load**, depends on initial bow imperfection of girder and compressive force in girder.



Girders are imperfected randolmly, in left or right. Total effect for entire roof is not:  
 (single effect) · (number of girders m)  
 but: (single effect) · (reduction factor  $\alpha_m$ ).

12 bands between trusses, **13 trusses**. **2** braced bands in roof  $\rightarrow m = 13 / 2 = 6,5$  trusses for one braced band.

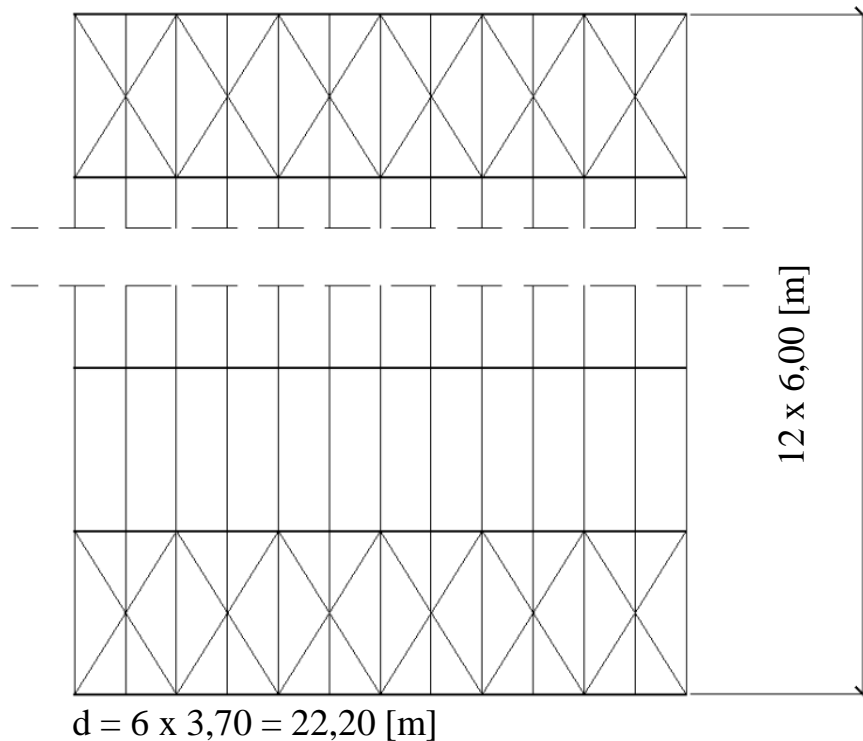

Reduction factor for effects from instability and imperfections (EN 1993-1-1 (5.12)):

$$\alpha_m = \sqrt{0,5 (1 + 1 / m)}$$

$$m = 6,5$$

$$\alpha_m = 0,760$$

Max compressive force in top chord of vertical truss:  $N_{Ed, c} = 302, 157 \text{ kN}$  ( $\rightarrow \#t / 45$ )

Buckling equivalent force from truss chord to bracings (EN 1993-1-1 5.3.3.(4)): :

$$F_{buck} = \alpha_m N_{Ed, c} / 100 = 2,296 \text{ kN}$$

Photo: Author

Initial horizontal bow imperfection for truss chord (EN 1993-1-1 (5.12)):

$$e_0 = \alpha_m d / 500 = 33,744 \text{ mm.}$$

Initial bow imperfection is recalculated to equivalent forces according to specific algorithm.

Two alternative schemes of action are taken into consideration:

- wind and equivalent effects from buckling;
- wind and equivalent effects from imperfections.

For final analysis more important will be bigger value of both above.

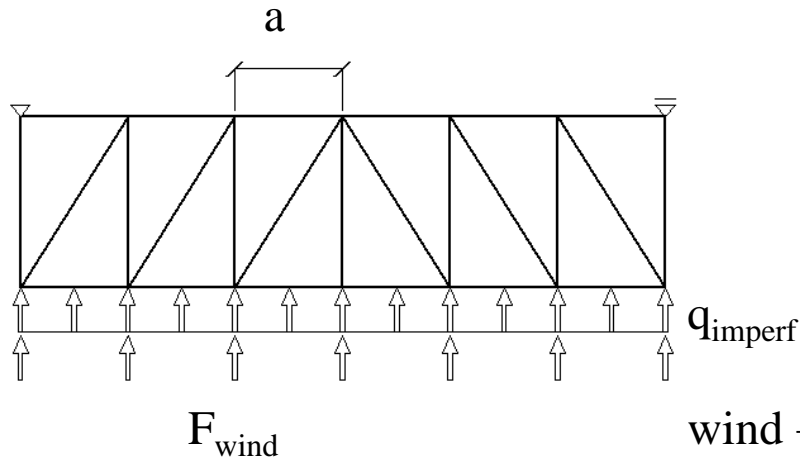

$q_{imperf}$  is of course applied to structure as:

$$F_{imperf} = a \cdot q_{imperf}$$

wind + imperfection

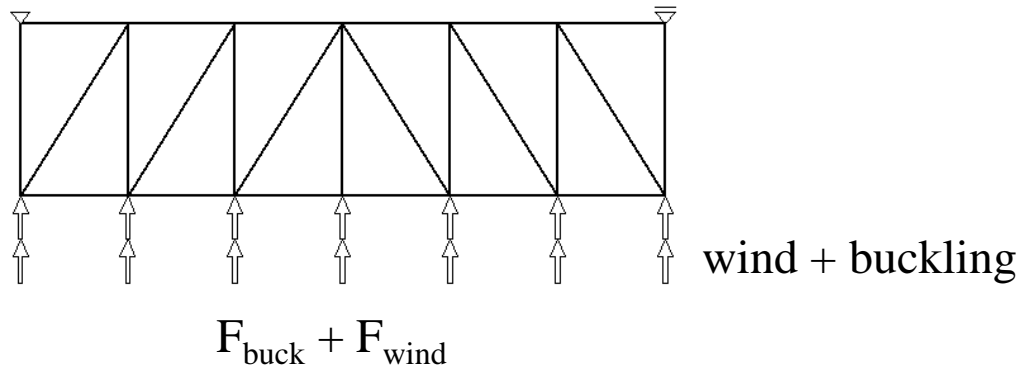

wind + buckling

Photo: Author

Calculation of equivalent loads from imperfection  $q_{\text{imperf}}$  for roof bracings is complicated. According to EN 1993-1-1 (5.13), total equivalent load (from wind and imperfection) is calculated as:

$$q_{\text{imperf}} = q_d = \Sigma [8 N_{\text{Ed}, c} (e_0 + \delta_q) / L^2]$$

$\delta_q$  – deformation comes from load  $q_d$

Total load  $q_d$  depends on  $\delta_q$ , but  $\delta_q$  is the effect of  $q_d$ . Such problem can be solved by iteration procedure:

$$\delta_q^{(0)} = \delta(q_q) = \delta_q = \text{deflection from wind only} = \delta_w$$

$$q_d^{(0)} = q_d^{(0)}(e_0 + \delta_q^{(0)}) = \Sigma [8 N_{\text{Ed}, c} (e_0 + \delta_q^{(0)}) / L^2]$$

$$\delta_q^{(1)} = \delta_q^{(1)}(q_d^{(0)}) \text{ static calculation: deflection}$$

$$q_d^{(1)} = q_d^{(1)}(e_0 + \delta_q^{(1)} + \delta_w) = \Sigma [8 N_{\text{Ed}, c} (e_0 + \delta_q^{(1)} + \delta_w) / L^2]$$

$$\delta_q^{(2)} = \delta_q^{(2)}(q_d^{(1)}) \text{ static calculation: deflection}$$

$$q_d^{(2)} = q_d^{(2)}(e_0 + \delta_q^{(2)} + \delta_w) = \dots$$

...

$q_d$  is of course applied to structure as:

$$F_d = a \cdot q_d$$

Iteration: static calculations of bracings must be made few times for iteration procedure.

Step 0: deformation for wind only

Photo: Author

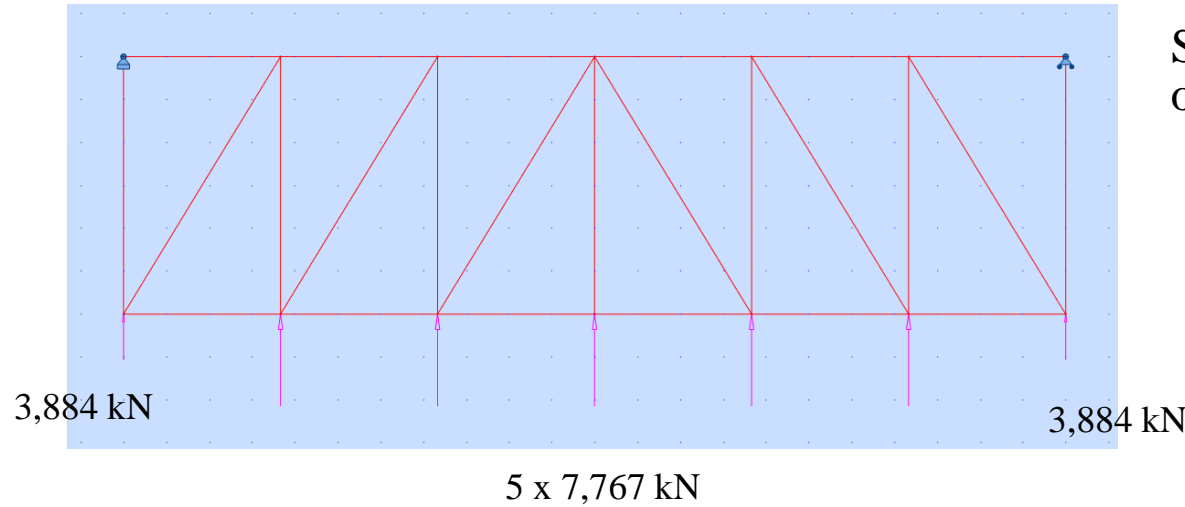

$$\delta_q^0 = \delta(q_{\text{wind}}) = 2 \text{ mm}$$

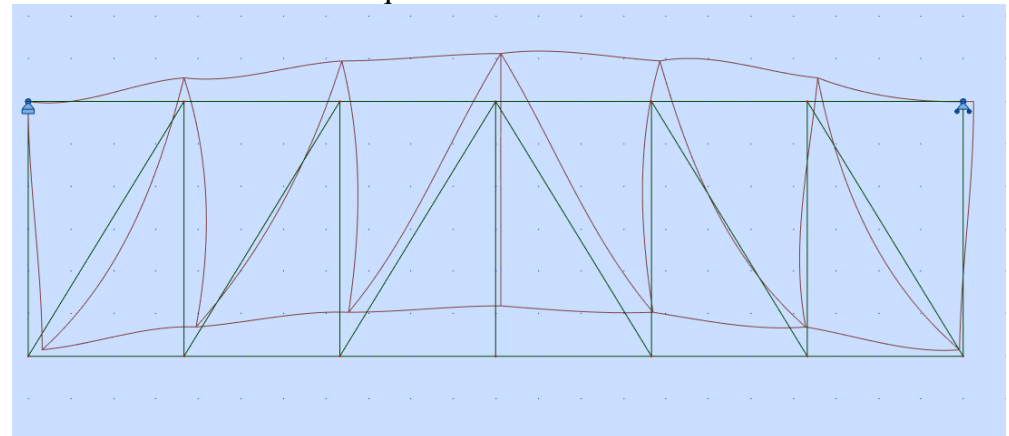
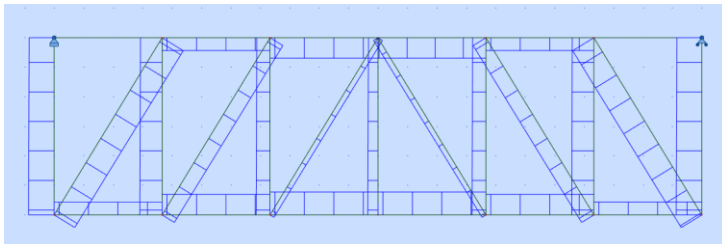

# Steps of iteration:

$$\delta_q^0 = \delta(q_{wind}) = 2 \text{ mm}$$

$$q_d^{(0)} = \Sigma [8 N_{Ed, c} (e_0 + \delta_{wind}) / L^2] =$$

$$= 6 \cdot 8 \cdot 302,157 \text{ [kN]} \cdot (33,744 \text{ [mm]} + 2 \text{ [mm]}) / (22,2 \text{ [m]})^2 = 1,052 \text{ kN / m}$$

$$\rightarrow \text{force} = 3,70 \cdot 1,052 = 3,892 \text{ kN}$$

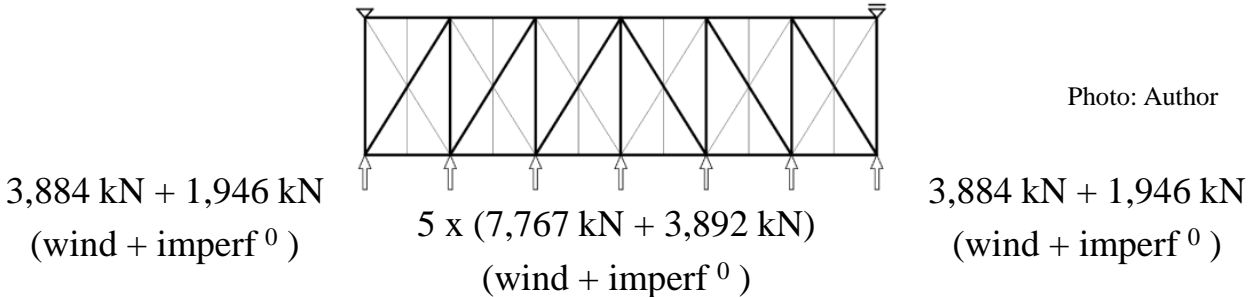

## Static calculation of deformation

$$\delta_q^{(1)} = \delta_q^{(1)}(q_d^{(0)}) = 3 \text{ mm}$$

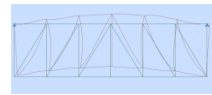

Photo: Author

$$q_d^{(1)} = \Sigma [8 N_{Ed, c} (e_0 + \delta_q^{(1)} + \delta_{wind}) / L^2] =$$

$$= 6 \cdot 8 \cdot 302,157 \text{ [kN]} \cdot (33,744 \text{ [mm]} + 2 \text{ [mm]} + 3 \text{ [mm]}) / (22,2 \text{ [m]})^2 = 1,199 \text{ kN / m}$$

$$\rightarrow \text{force} = 3,70 \cdot 1,199 = 4,436 \text{ kN}$$

Steps of iteration:

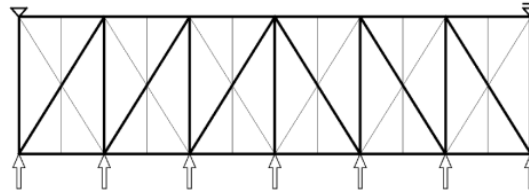

Photo: Author

$$3,884 \text{ kN} + 2,218 \text{ kN}$$

(wind + imperf<sup>1</sup>)

$$5 \times (7,767 \text{ kN} + 4,436 \text{ kN})$$

(wind + imperf<sup>1</sup>)

$$3,884 \text{ kN} + 2,218 \text{ kN}$$

(wind + imperf<sup>1</sup>)

Static callulation of deformation

$$\delta_q^{(2)} = \delta_q^{(2)}(q_d^{(1)}) = 3 \text{ mm}$$

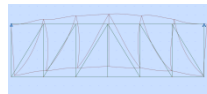
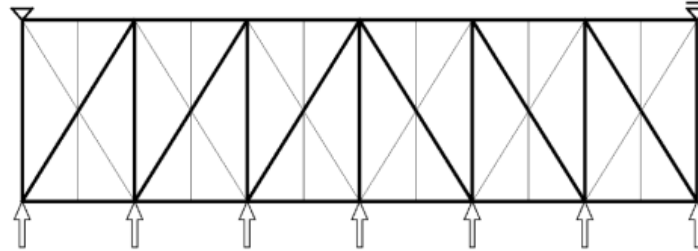

Photo: Author

No difference, end of iteration.

Two combinations must be taken into consideration: wind + equivalent effects of buckling:

Photo: Author



$$3,884 \text{ kN} + 1,149 \text{ kN} = \underline{5,033 \text{ kN}}$$

$$3,884 \text{ kN} + 1,149 \text{ kN} = \underline{5,033 \text{ kN}}$$

$$5 \times (7,767 \text{ kN} + 2,296 \text{ kN}) = 5 \times \underline{10,063 \text{ kN}}$$

Wind + equivalent effects of imperfections:

Photo: Author

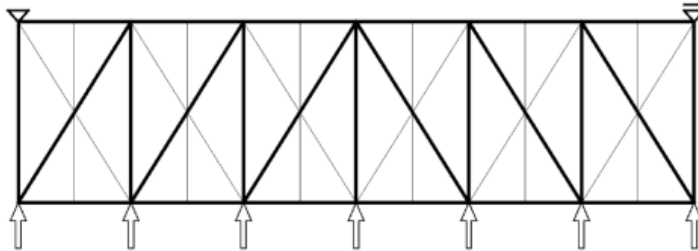

$$3,884 \text{ kN} + 1,946 \text{ kN} = \underline{5,830 \text{ kN}}$$

$$3,884 \text{ kN} + 1,946 \text{ kN} = \underline{5,830 \text{ kN}}$$

$$5 \times (7,767 \text{ kN} + 3,892 \text{ kN}) = 5 \times \underline{11,659 \text{ kN}}$$

Forces for the second one are bigger → the second is important for calculations of horizontal bracing.

Max compressive force in purlin:  $N_{Ed, c, p} = 24,17 \text{ kN}$

Final results:

Photo: Author

Max tensile force in chord:  $N_{Ed, c, ch} = 18,46 \text{ kN}$

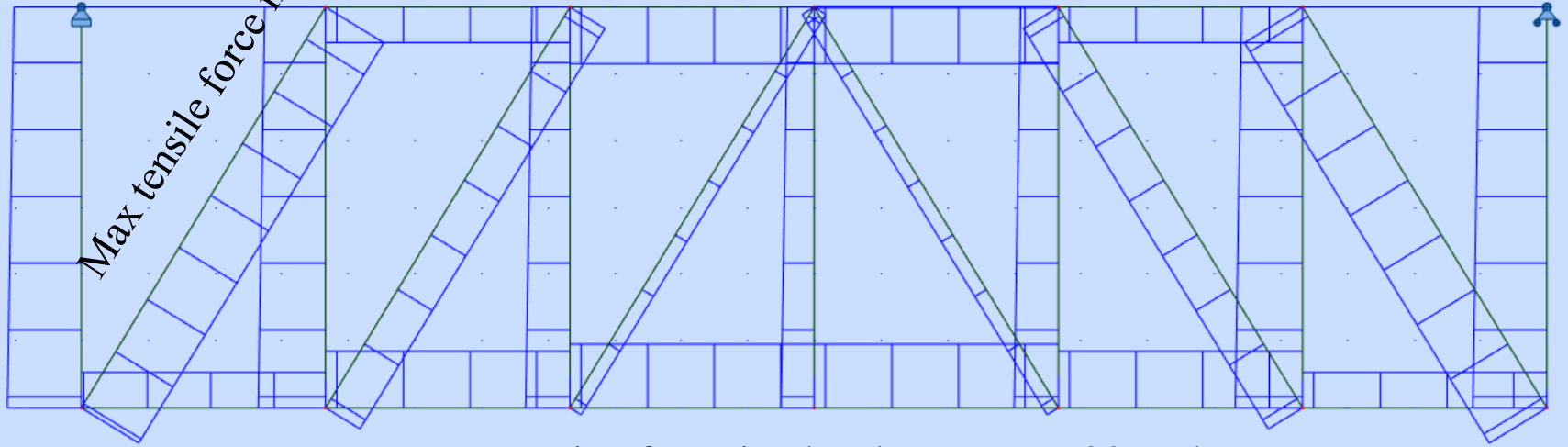

Max tensile force in bracing:  $N_{Ed, t, b} = 22,02 \text{ kN}$

Max compressive force in chord:  $N_{Ed, t, ch} = 20,77 \text{ kN}$

## Checking of resistance: round bar (tensile force only) $\phi$ 25

$$N_{Rd, bb} = f_y A / \gamma_{M0} = 115,355 \text{ kN}$$

$$N_{Ed, c, bb} / N_{Ed, bb} = 0,191 \quad \text{👍}$$

## Checking of resistance: purlin

Purlin was calculated as bi-axial bending element ( $\rightarrow$  #t / 18-26). At now, should be recalculated to case „bi-axial bending and compressive force”. In Your range of project it is enough to ensure requirement  $E / R \leq 0,8$  ( $\rightarrow$  #t / 28).

## Chords of roof bracings.

Both chords of roof bracings (horizontal truss) are simultaneously top chords of main trusses (vertical trusses). New values of forces in trusses must be taken into consideration as additional forces applied to trusses.

Simplification for new values of forces:

Max compressive force from bracings (20,77 kN) together with combination of loads which gives max compression in top chord (302,157 kN).

Max tensile force from bracings (18,46 kN) together with combination of loads which gives max tension (or min compression) in top chord (55,112 kN).

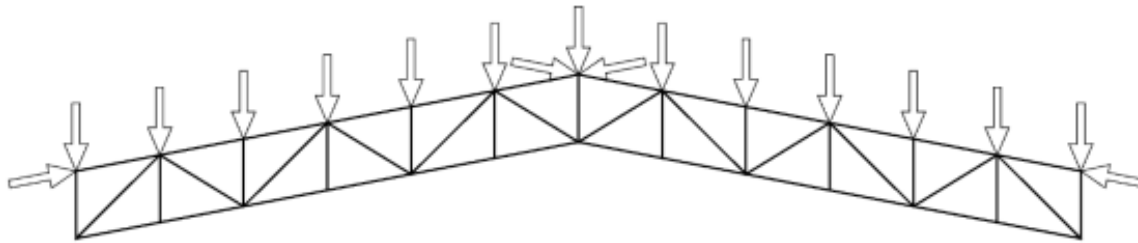
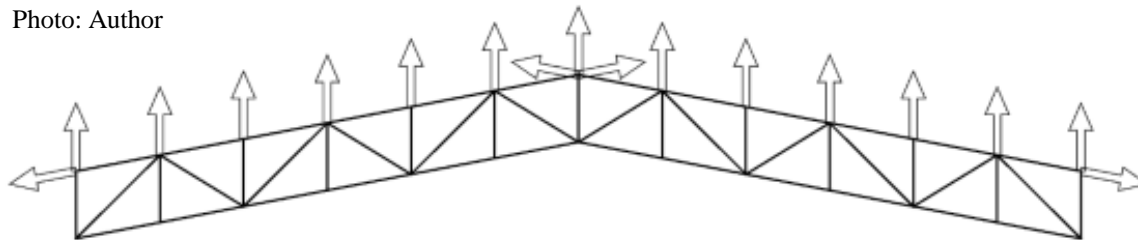

Photo: Author



Simplification: in fact, changes will be smaller, because bottom chord cooperates with top chord and will take over some of new forces.

## New forces in chords

Initial situation:

Chord	Max tension [kN]	Max compression [kN]	Cross-section
Top	-55,112	302,157	Hot-rolled CHS 108x10
Bottom	-304,853	52,789	

Change as the effect of cooperation with bracigs:

Max compressive force in chord from bracings:  $N_{Ed, c, ch} = 20,77$  kN

Max tensile force in chord from bracings :  $N_{Ed, t, ch} = -18,46$  kN

New values of forces:

Chord	Max tension [kN]	Max compression [kN]	Cross-section
Top	-73,572	322,927	Hot-rolled CHS 108x10
Bottom	-304,853	52,789	

## Checking conditions

Chord	E / R - tension	E / R – compression + in plane buckling	E / R - compression + out of plane buckling
Top	0,102	0,482	0,755
Bottom	0,421	0,081	0,410

Deflection: 4 mm

In EU 1993-1-1 there is no condition for bracing deformation. Assuming the same as for truss, permissible value  $L / 250 = 88,8$  mm

$$4 / 88,8 = 0,045 \text{ 👍}$$

Thank you for attention

© 2025 Tomasz Michałowski, PhD

[tmichal@pk.edu.pl](mailto:tmichal@pk.edu.pl)